

THE SMARTMEASURE-AL

Empower your production facility using a highly automated and user-friendly solution from Mitutoyo



SmartMeasure-AL

The SmartMeasure-AL is an advanced system designed for automatic measurements on Mitutoyo measuring machines. The complete system includes a pick-up rack, an I/O station, a storage system, system pallets, a collaborative robot, and a CMM (with a data processing PC). The collaborative robot and CMM must be purchased separately.



Features

- **Efficient Measurement:** The system allows for automatic measurements even during nighttime, which not only increases efficiency, but also addresses the shortage of manpower. The operator simply needs to place the workpiece on the pallet, configure some measurement parameters, and let the system run autonomously.
- **Easy to Operate:** With our Space4Win software and an easy and user-friendly GUI, an operator without knowledge of the system can easily run the whole setup.
- **Re-measure:** With help of the user-friendly software, the operator can easily re-measure parts that are NOT OK without having to run the whole sequence again.
- **Result Display:** The measurement result is displayed via an indicator light on the HMI (green light for OK, red light for NOT OK).
- **Program Selection:** The part program can be automatically selected by reading the RFID tag mounted on the pallet and by using the RFID reader mounted on the robot gripper.
- **Flexible Configuration:** The combination of RFID tag and the part program can be modified simply by editing the settings file.
- **Connectivity :** Once measurement is completed, measurement results can be sent to statistical software or even to external software. Moreover, results can be send directly to CNC machines for tool correction with our Space4Win software.

Automatic Quality Control System



Turnkey Solution

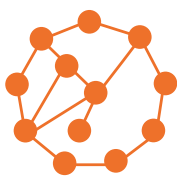

Smart Connectivity



Modular Configuration



24/7 Operation



The SmartMeasure-AL is designed for ease of use: modern technology like the RFID and anti-collision sensor makes the SmartMeasure-AL a compact and reliable solution.

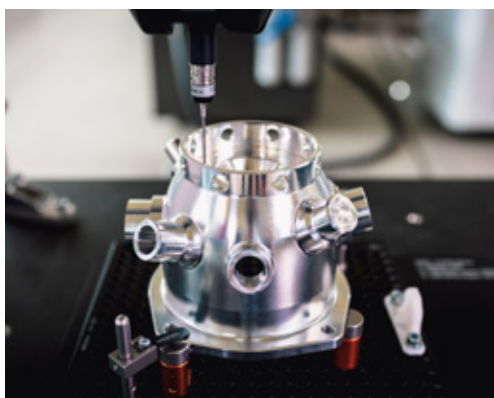

Picture from part fixed to a CMM



Anti-collision sensor



RFID sensor

24/7 OPERATION

The SmartMeasure-AL can be operated 24/7 without operator influences, thus increasing productivity and production throughput.

EASY REPORTING

After each operation, measurement reports/results can be outputted to a specified location. Connection to production manufacturing platforms can be also done.

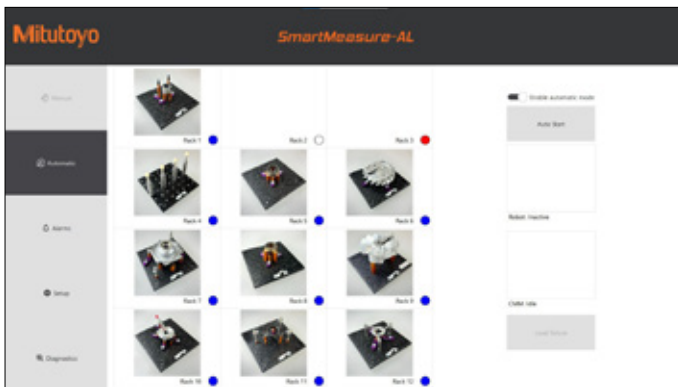

Dimensions

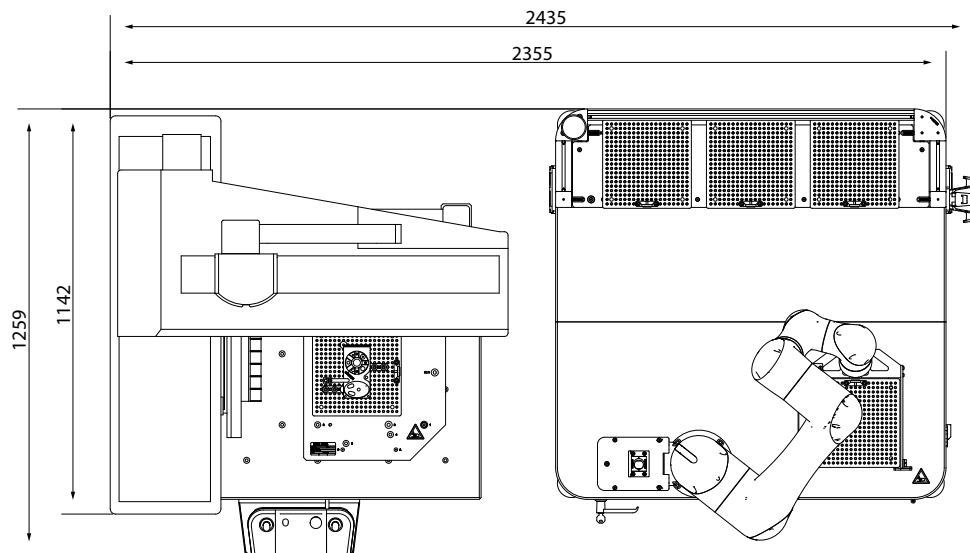

Unit: mm

Footprint, MiSTAR555 with SmartMeasure-AL

CMM Type	Width	Depth
MiSTAR 555	2355 mm	1142 mm
MiSTAR 575	2355 mm	1322 mm
CRYSTA-Apex V544	2337 mm	1233 mm
CRYSTA-Apex V574	2337 mm	1548 mm
CRYSTA Apex V 776	2705 mm	1697 mm
CRYSTA Apex V 7106	2705 mm	1997 mm
CRYSTA Apex V 9106	2805 mm	1997 mm

Application Examples

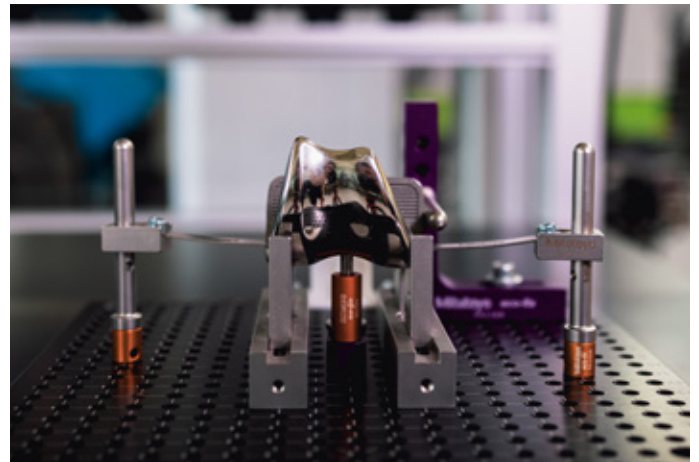
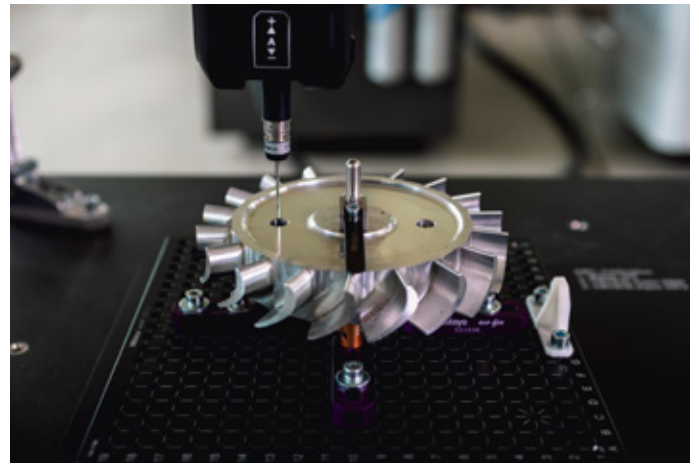
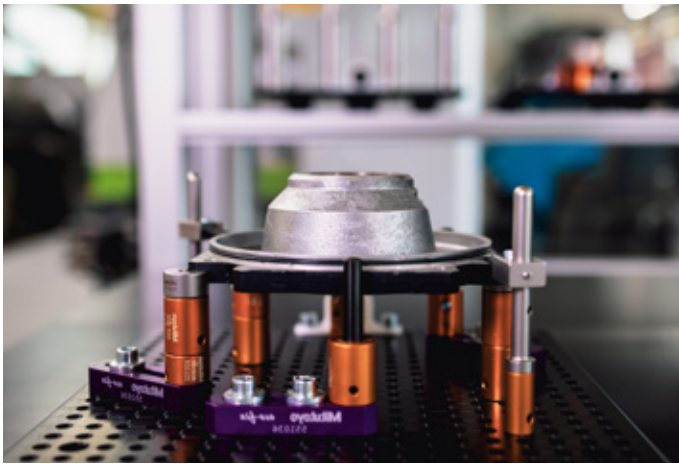

The Perfect Solution Regardless of Industry

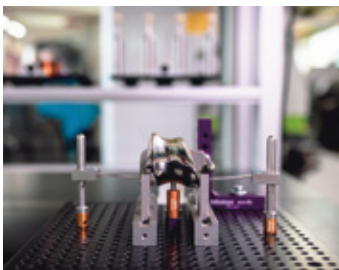

Medical

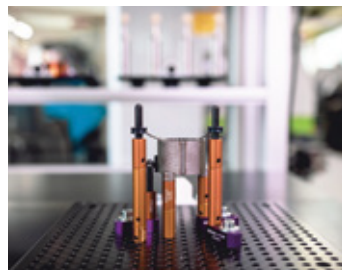

Automotive



Additive Manufacturing

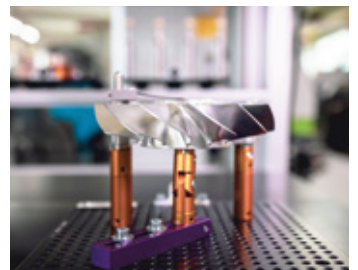

Aerospace

Configuration



1. CMM Configuration

Product Name	Article Number	Remark
MiSTAR 555*	357-305	Probes, styli, and software module shall be configured according to application
MiSTAR 575*	357-313	
CRYSTA-Apex V544*	191-121	
CRYSTA-Apex V574*	191-125	
CRYSTA Apex V 776*	191-561	
CRYSTA Apex V 7106*	191-565	
CRYSTA Apex V 9106*	191-569	

* For technical specification of CMM please refer to technical specification sheet

2. SmartMeasure-AL Configuration

Product Name	Article Number	Remark
SmartMeasure-AL	K543869*	Please refer to specification sheet for detail information

*CMM, CMM accessories, and robot need to be ordered separately

3. Robot Configuration

Technical Specification	Robot	
	CRX-10iA/L *	CRX-20iA/L *
Manufacturer	FANUC	FANUC
Robot type (model)	CRX-10iA/L *	CRX-20iA/L *
Reach	1.418 mm	1.418 mm
Controller type (model)	R-30iB Mini Plus	R-30iB Mini Plus
Limiting operating speed	250 mm/s	250 mm/s
Payload	10 kg	20 kg
Repetitive positioning accuracy	±0.04 mm	±0.04 mm

* Robot needs to be ordered with profinet configuration



Whatever your challenges are, Mitutoyo supports you from start to finish.

Mitutoyo is not only a manufacturer of top-quality measuring products but one that also offers qualified support for the lifetime of the equipment backed up by comprehensive services, ensuring your staff can make the very best use of the investment.

Apart from the basics of calibration and repair, Mitutoyo offers product and metrology training, as well as IT support for the sophisticated software used in modern measuring technology. We can also design, build, test, and deliver bespoke measuring solutions and even, if deemed cost-effective, take your critical measurement challenges in-house on a sub-contract basis.

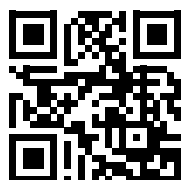

Find additional product literature and our complete catalog here.

www.mitutoyo.eu

Note: Product illustrations are without obligation. Product descriptions, in particular all technical specifications, are only binding when explicitly agreed upon. MITUTOYO and MiCAT are either registered trademarks or trademarks of Mitutoyo Corp. in Japan and/or other countries/regions. Other product, company, and brand names mentioned herein are for identification purposes only and may be the trademarks of their respective holders.

Mitutoyo

Mitutoyo Europe GmbH

Borsigstraße 8-10
41469 Neuss

Tel. +49 (0) 2137-102-0

info@mitutoyo.eu
www.mitutoyo.eu