

Compact Roundness Measurement ROUNDTTEST RA-120/120P



Roundtest RA-120

This compact roundness measuring machine is provided with numerous user-friendly features aimed at prioritizing usability, such as a wider range for the detector, an easy-to-understand operation panel with large LCD, a D.A.T. function that powerfully supports centering and leveling adjustments, and so on.

- Best-in-class rotational accuracy in compact type roundness measuring instruments
- Fine adjustment on both X- and Z-axes
- Multiple analyses through simple operation
- D.A.T. function*1
- Scaled Z-axis*1
- Continuous ID and OD measurement*1
- High-precision air bearing
- Wide-range detector*2
- Registration and calling of measurement results/conditions
- Built-in printer
- Supports 16 languages

*1: Refer to P.6
*2: Refer to P.7



Simple, interactive display screen

The large LCD screen with backlight shows easy-to-understand measurement results and graphs. Forms can be checked and notch processing can be set while observing the displayed graphs.

Measurement screen

- Set the position of the detector and measurement conditions here
- During measurement, graphs are displayed in real time

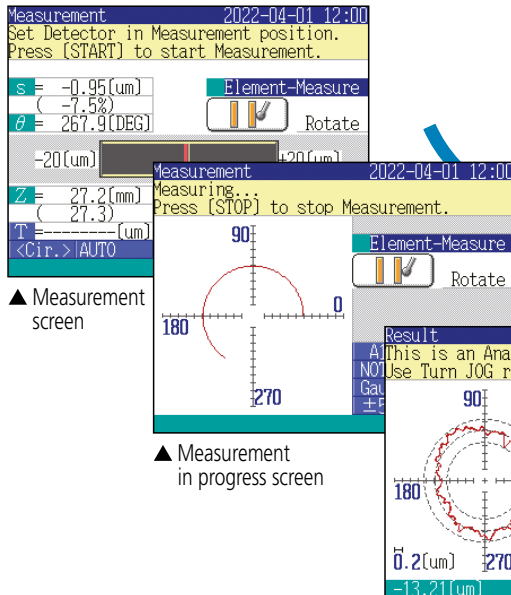

Measurement results

- Filter, display magnification, etc., can be altered
- Besides circles, development views can also be displayed

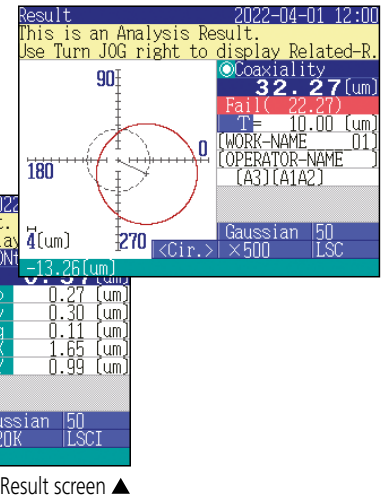

Operating panel that is read at a glance

Supports 16 languages

Japanese, English, German, French, Italian, Spanish, Portuguese, Korean, Traditional Chinese, Simplified Chinese, Czech, Polish, Hungarian, Turkish, Swedish, Dutch

Analysis type

Selection buttons provide access to a wide variety of analysis types

Switching screen modes

Switch the display at the touch of a button, providing access to the [Calibration], [Centering and Leveling], [Measurement], and [Result] screens.

Zero-setting button

No fine adjustment necessary for setting the measurement position

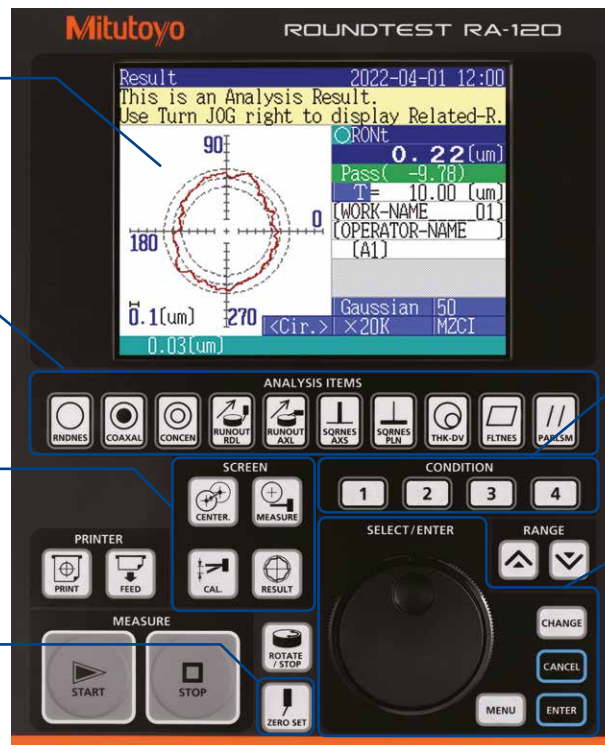

Simple setup

Apply the current measurement setup in one go
Simple operation helps prevent operational errors

Log dial

Make detailed changes to setup and other operations

Simplified communication program for ROUNDTEST RA-120

The Roundtest RA-120 has a USB interface, enabling data to be transferred to a spreadsheet or other software.

Notch processing

Unwanted data, such as that produced by notches or scratches, can be excluded from the analysis if desired. Select between [Automatic setting] and [Arbitrary setting].

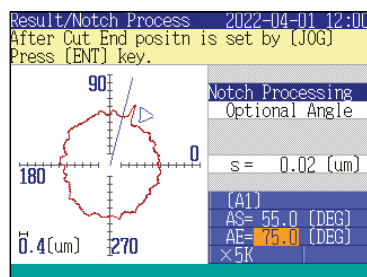

File save

Save and access [Measurement files] and [Result files] in USB memory. Data can also be totaled using the data output function with commercial tabulation software.

[Measurement file] [Measurement data (Data output)]
[Result file] [Result data (Data output)]

High-grade thermal printer

Print measurement conditions, computation results, result graphs, comments, etc., to the thermal printer. Change development graphs and output items as desired.

■ Sample prints

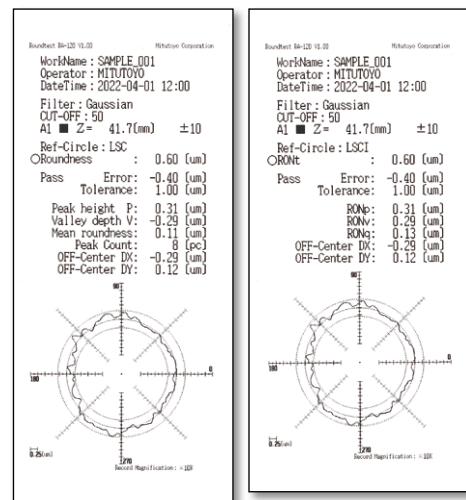

Recording paper set (optional set of 10 rolls)

Roundtest RA-120P

This entry-level desktop tester incorporates the ROUNDPAK multi-analysis evaluation program, which provides it with analytical power close to that of more elaborate models. This is, therefore, a highly functional multi-analysis roundness measuring machine that is suitable for use not only in measurement rooms, but also in research and development sections.

- Best-in-class rotational accuracy in the Compact Type Roundness Measuring Instruments
- Fine adjustment on both X- and Z-axes
- Multiple analyses through simple operation
- D.A.T. function*1
- Scaled Z-axis*1
- Continuous ID and OD measurement*1
- Display function for various graphs
- High-precision air bearing
- Wide-range detector*2
- Supports 18 languages

*1: Refer to P.6
*2: Refer to P.7



Windows graphical interface

By using a mouse and buttons, identified by corresponding icons, to control the machine, the Roundtest RA-120P's interface provides excellent usability. Functions such as recalculation and graph reading are handled swiftly with easy-to-understand operations.

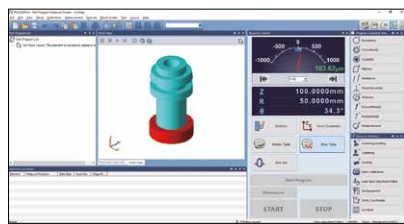

▲ Main screen



▲ Measurement setup screen

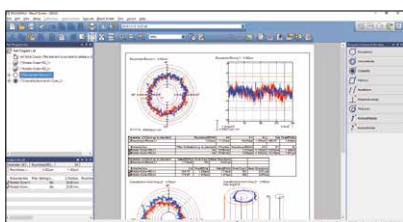

▲ Result screen



▲ Measurement in progress screen

This entry-level desktop tester incorporates the ROUNDPAK multi-analysis evaluation program, which provides it with analytical power close to that of more elaborate models. This is, therefore, a highly functional multi-analysis roundness measuring machine that is suitable for use not only in measurement rooms, but also in research and development sections.

Measurement screen makes ample use of graphs

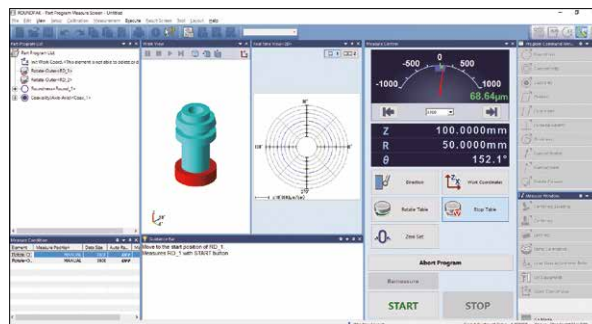

Multi-analysis function

Complete with a wide range of functions including partial enlargement, auxiliary line setup, color change, displacement/angular difference of data between two points, and so on. Also equipped with notch processing and graph reading functions, which make the machine useful in research departments. Recalculation can also be performed with the filter and evaluation method changed.

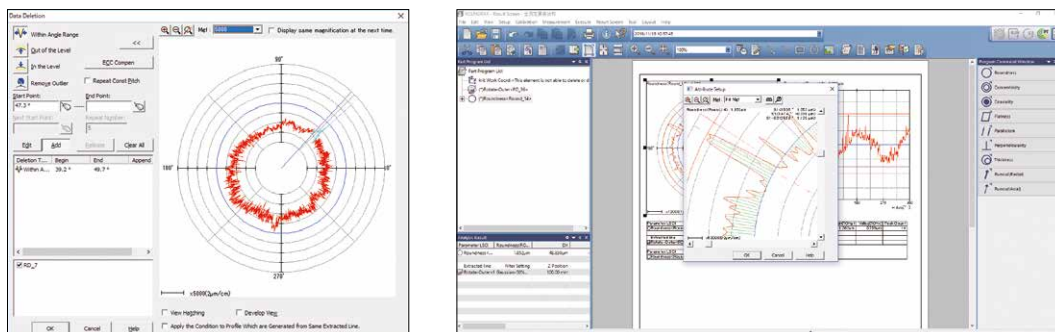

Simplified layout function

Computation results for multiple items can be laid out in multiple forms on a single sheet and printed.

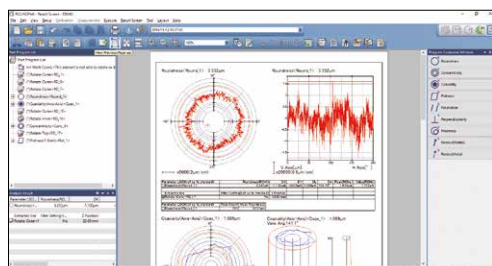

■ Layout setting screen

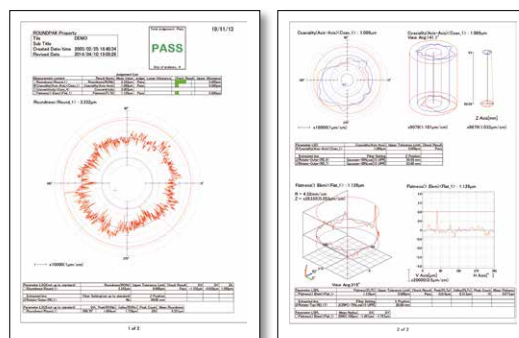

■ Sample print outputs

Functions that implement greater efficiency of measurement and range of analysis types

D.A.T. function *except for centering/leveling device equipped with analog micrometer heads

This instrument uses the D.A.T. (Digital Adjustment Table) function available on more sophisticated models, and this provides powerful support for centering and leveling operations. To perform such operations, the user need only adjust the digital micrometer heads attached to the rotary table by the amounts indicated by the display. This function also supports measurement of notched workpieces.

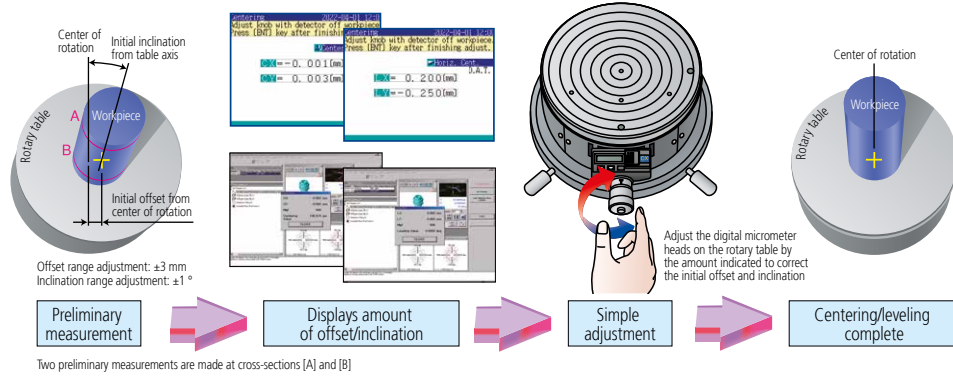
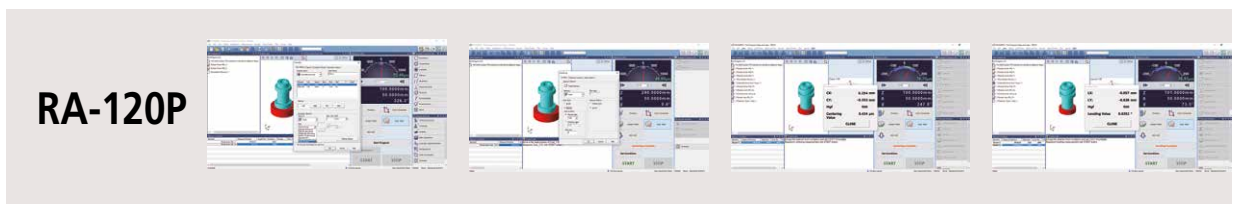
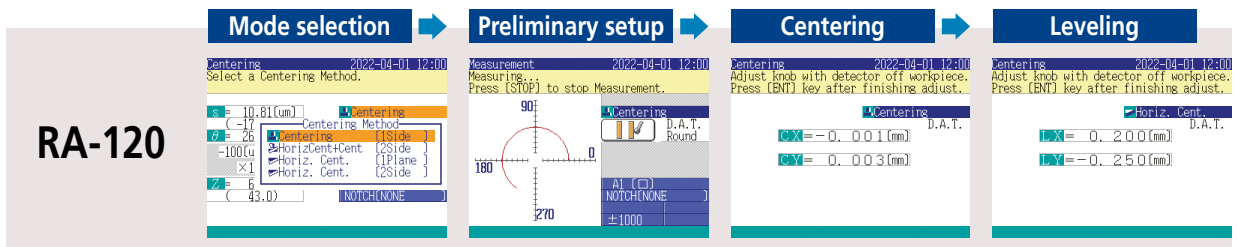

Continuous ID and OD measuring function

This function comes in very handy when outside diameter and inside diameter surfaces need to be measured repeatedly, for example, with respect to concentricity, deviation in wall thickness, etc. The inner surface can be measured and evaluated with the detector, maintaining the same measuring position for the outside diameter without changing its orientation, as illustrated on the right. Inside diameters down to 50 mm can be measured.



Continuous inside and outside diameter function (inside dia. surface)

Continuous inside and outside diameter function (outside dia. surface)

Z-axis scale

This scale is useful when the measuring height position needs to be entered, such as when measuring concentricity, etc. The machine uses an ABS Digimatic scale unit to provide an effective means for repetitive measurement and position setting.



IN/OUT switchable wide-range detector

The range of this detector has been extended from that of a conventional lever head by as much as four times, and is now wider than ever before. The detector can provide sufficient margin for centering and leveling jobs, or when measuring large differences. Moreover, the measuring direction can be switched between inside and outside diameters with a single touch of a button.

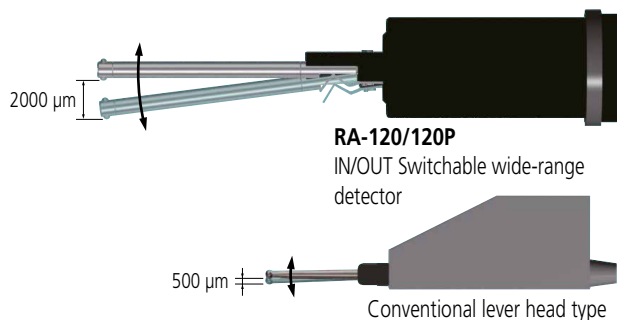

Types of Analysis

Type of Analysis	Measurement mode	Evaluation diagram	RA-120	RA-120P	Type of Analysis	Measurement mode	Evaluation diagram	RA-120	RA-120P	
Roundness			✓	✓	Parallelism			✓	✓	
Flatness			✓	✓	Thickness variation	Radial			✓	✓
Perpendicularity	Relative to axis		✓	✓		Axial			✓	✓
	Relative to plane		✓	✓	Circular run-out	Radial			✓	✓
Concentricity			✓	✓		Axial			✓	✓
Coaxiality	of section		✓	✓	Power spectrum			—	✓	
	of axis		—	✓	Profile operation			—	✓	

Optional Accessories

Interchangeable Styli*

Unit: mm

<p>12AAL021 Standard accessory Standard stylus (stylus tip: $\phi 1.6$ carbide ball)</p> <p>For standard applications</p> <p>In ID measurement Dia.: ≥ 7.5 mm, Depth: ≤ 50 mm</p>	<p>12AAL022 Stylus for notched workpieces (stylus tip: $\phi 3$ carbide ball)</p> <p>Useful for notched workpieces</p> <p>Example</p>	<p>12AAL023 Stylus for grooves (stylus tip: R0.25 sapphire)</p> <p>For stepped applications</p> <p>Example</p>	<p>12AAL024 Stylus for corners (stylus tip: R0.25 sapphire)</p> <p>For inside-corner applications</p> <p>Example</p>
<p>12AAL029 Stylus for extra small holes (stylus tip: $\phi 0.5$ carbide ball)</p> <p>For extra small hole applications Dia.: ≥ 1 mm, Depth: ≤ 2.5 mm</p> <p>Enlarged image</p> <p>$\phi 0.5$ carbide ball</p>	<p>12AAL026 Stylus for small holes (stylus tip: $\phi 0.8$ carbide ball)</p> <p>For small hole applications Dia.: ≥ 1.5 mm, Depth: ≤ 10 mm</p> <p>Enlarged image</p> <p>$\phi 0.8$ carbide ball</p>	<p>12AAL030 Stylus for small and deep holes (stylus tip: $\phi 1.6$ carbide ball)</p> <p>For small and deep hole applications Dia.: ≥ 3 mm, Depth: ≤ 18 mm</p> <p>Enlarged image</p> <p>$\phi 1.6$ carbide ball</p>	<p>12AAL028 Stylus for small and deep holes (stylus tip: $\phi 1.6$ carbide ball, L=40)</p> <p>For small and deep hole applications Dia.: ≥ 3 mm, Depth: ≤ 38 mm</p> <p>Enlarged image</p> <p>$\phi 1.6$ carbide ball</p>
<p>12AAL027 Stylus for small holes (stylus tip: $\phi 1$ carbide ball)</p> <p>For small hole applications</p> <p>Example</p> <p>$\phi 1$ carbide ball</p>	<p>12AAL032 Cranked stylus (stylus tip: $\phi 0.5$ carbide ball)</p> <p>For upper/lower surface in a narrow groove</p> <p>Note: This stylus cannot be used for OD/ID measurement.</p>	<p>12AAL033 Cranked stylus (stylus tip: $\phi 1$ carbide ball)</p>	<p>12AAL034 Stylus for flat surface</p> <p>Example</p>
<p>12AAL025 Cutter mark stylus - R15 mm</p> <p>Filtering out the effects of asperities by tracing with R15 tipped stylus</p> <p>Example</p> <p>Machining marks</p>	<p>12AAL031 Disc stylus D12 mm</p> <p>Example For narrow groove applications</p>	<p>12AAL043 Stylus shank for mounting M2-CMM</p> <p>Compatible with CMM styli with M2 threaded shank</p> <p>M2 depth 5</p>	<p>12AAL044 Groove stylus shank for mounting M2-CMM</p> <p>Compatible with CMM styli with M2 threaded shank</p>

*Customized special interchangeable styli are available on request. Please contact any Mitutoyo office for more information.

Quick chuck (knurled ring operated)

Provides good operability when measuring a small-diameter workpiece. The knurled ring allows the workpiece to be clamped easily.



Order No.	211-032
Holding range	OD with inner jaw: $\phi 1 - 36$ mm ID with inner jaw $\phi 16 - 69$ mm OD with outer jaw: $\phi 25 - 79$ mm
External size (D x H)	$\phi 118 \times 41$ mm
Mass	1.2 kg

Collet chuck holder

Provides high clamping repeatability due to the use of optional precision collets. (See table at right.)



Order No.	211-061
Part holding range	OD $\phi 0.5 - 10$ mm*2
Centering error	Within $50 \mu\text{m}$ *3
Mass	1.4 kg

*2: Collets to match the workpiece size range are required for use with this chuck.

*3: When measured with $\phi 5$ mm pin gauge at measuring height of 30 mm.

X-axis stop

Allows the user to return the detector rapidly and easily to a fixed position in the X axis.



Order No.	12AAH320
Mass	65 g

USB Communication Program for ROUNDTTEST RA-120

The Roundtest RA-120 has a USB interface, enabling data to be transferred to a spreadsheet or other software. We also provide a program that lets you create inspection record tables using a Microsoft Excel* macro.

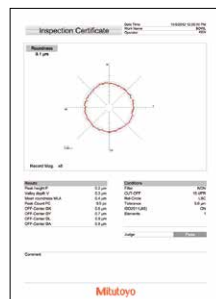
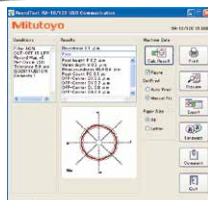

Three-jaw chuck (key operated)

Useful where it is necessary to apply a higher clamping force to the workpiece than can be applied with the centering chuck.



Order No.	211-014
Holding range	OD with outer jaw: $\phi 2 - 35$ mm ID with inner jaw: $\phi 25 - 68$ mm OD with outer jaw: $\phi 35 - 78$ mm
External size (D x H)	$\phi 157 \times 70.6$ mm
Mass	3.8 kg

Individual collets*4

These collets are for use with the collet chuck shown at left and are acquired to match the workpiece diameter range required.

Order No.	Part Holding Range
12AAH402	$\phi 0.5 - 1.0$ mm
12AAH403	$\phi 1.0 - 1.5$ mm
12AAH404	$\phi 1.5 - 2.0$ mm
12AAH405	$\phi 2.0 - 2.5$ mm
12AAH406	$\phi 2.5 - 3.0$ mm
12AAH407	$\phi 3.0 - 3.5$ mm
12AAH408	$\phi 3.5 - 4.0$ mm
12AAH409	$\phi 4.0 - 5.0$ mm
12AAH410	$\phi 5.0 - 6.0$ mm
12AAH411	$\phi 6.0 - 7.0$ mm
12AAH412	$\phi 7.0 - 8.0$ mm
12AAH413	$\phi 8.0 - 9.0$ mm
12AAH414	$\phi 9.0 - 10.0$ mm

*4: A collet cannot be mounted on the rotary table without a collet chuck.
4: YCC10- Class AA, made by Yukiwa Seiko Inc. or its equivalent.

Vibration-damping stand



Order No.	211-013
Vibration damping system	Diaphragm type air spring
External size	615 x 515 x 51 mm
Max. loading mass	150 kg

Micro chuck

For clamping a small workpiece, 1 mm or less in diameter, that cannot be held in the centering chuck.



Order No.	211-031
Holding range	OD: $\phi 0.2 - \phi 1.5$ mm
External size (D x H)	$\phi 107 \times 48.5$ mm
Mass	0.6 kg

Auxiliary stage for low height workpiece

356038



Reference hemisphere

211-016



Magnification checking gage

211-045



Gage block set for calibration

997090



Printer paper set (10 rolls)

12AAH181

Replacement elements for the air filter

358592 (for filter)
358593 (filter regulator)

Required environment:

- OS: Windows XP-SP3
- Windows VISTA
- Windows 7 (32bit/64bit)
- Windows 10
- Spreadsheet software: Microsoft Excel 2010
- Microsoft Excel 2016

*Windows OS and Microsoft Excel are products of Microsoft Corporation.

The optional USB cable is also required.

- USB cable for RA-120 series
- 12AAH490**

This program can be downloaded for FREE from the Mitutoyo website.
https://mitutoyo.eu/en_us/downloads/software-and-updates

Specifications

■ Main unit

Model		RA-120			RA-120P			
		Dedicated electronic analysis type			Data analysis by PC			
Turntable	Rotational accuracy	Radial	(0.04+6H/10000) μm H: Probing height (mm) JISB7451-1997					
		Axial	(0.04+6X/10000) μm X: Distance from the center of rotation (mm)					
	Rotational speed	6 rpm						
	Table diameter	150 mm						
	Centering range adjustment	±3 mm						
	Leveling range adjustment	±1 °						
	Centering/leveling device (micrometer head)	Analog head	Digital head (mm)	Digital head (inch/mm)	Analog head	Digital head (mm)	Digital head (inch/mm)	
	Maximum probing diameter	280 mm (380 mm in a reverse and vertical detector position)						
	Maximum workpiece diameter	440 mm						
	Maximum turntable loading	25 kg						
Vertical column (Z axis)	Vertical travel	280 mm from the turntable top						
	Maximum probing height	280 mm from the turntable top (480 mm in the reverse and vertical detector configuration)						
	Maximum probing depth	100 mm (minimum ID: 30 mm)						
Horizontal arm (X axis)	Horizontal travel	165 mm (Including a protrusion of 25 mm from the turntable rotation center)						
Detector	Measuring direction	Two directional (IN/OUT switchable)						
	Measuring range	±1000 μm						
	Measuring force	70 to 100 mN (±30 %)						
	Standard stylus (12AAL021)	Carbide ball, ø1.6 mm (.06 ")						
Electronic unit	Measuring range	8 steps: ±(1000, 500, 200, 100, 50, 20, 10, 5) μm						
	Magnification	X5 to X200,000			X1 to X500,000			
	Filter type	Phase corrected: Gaussian, 2CRPC75, 2CRPC50			Not phase corrected: 2CR75, 2CR50 Filter OFF			
	Cutoff value	15 upr, 50 upr, 150 upr, 500 upr 15-150 upr, 15-500 upr, 50-500 upr			15 upr, 50 upr, 150 upr, 500 upr 15-150 upr, 15-500 upr, 50-500 upr			
	Number of measuring sections	Maximum 5			Maximum 100			
	Evaluation type	Roundness, coaxiality, concentricity, flatness, circular run-out (radial/axial), Perpendicularity (relative to axis/plane), thickness deviation, parallelism						
	Reference circle for evaluation	LSC, MZC, MIC, MCC						
	Adjusting centering/leveling	DAT function (circular/multi-point switchable)						
	Functions	Notched measurement, re-calculation, limaçon error correction, continuous ID and OD measurement			Notched measurement, re-calculation, limaçon error correction, remarkable point analysis (gear), harmonic analysis, continuous ID and OD measurement			
	Printer	Built-in thermal line printer			Windows compatible ink-jet printer			
	Display languages	Japanese, English, German, French, Italian, Spanish, Portuguese, Korean, Traditional Chinese, Simplified Chinese, Czech, Polish, Hungarian, Turkish, Swedish, Dutch			Japanese, English, German, French, Italian, Spanish, Portuguese, Korean, Traditional Chinese, Simplified Chinese, Czech, Polish, Hungarian, Turkish, Swedish, Russian, Dutch, Thai			
	Data output	USB	Calculation result, measurement data					
		RS-232C	Calculation result, measurement data					
SPC		Calculation result						
Others	Power supply	AC 100 – 240 V						
	Power consumption	32 – 36 W			21 – 24 W (excluding PC system)			
	Air pressure	0.39 MPa						
	Air consumption	30 L/min (minimum)						
	Mass	Main unit: 32 kg Air filter: 2 kg						

Dimensions

External dimensions

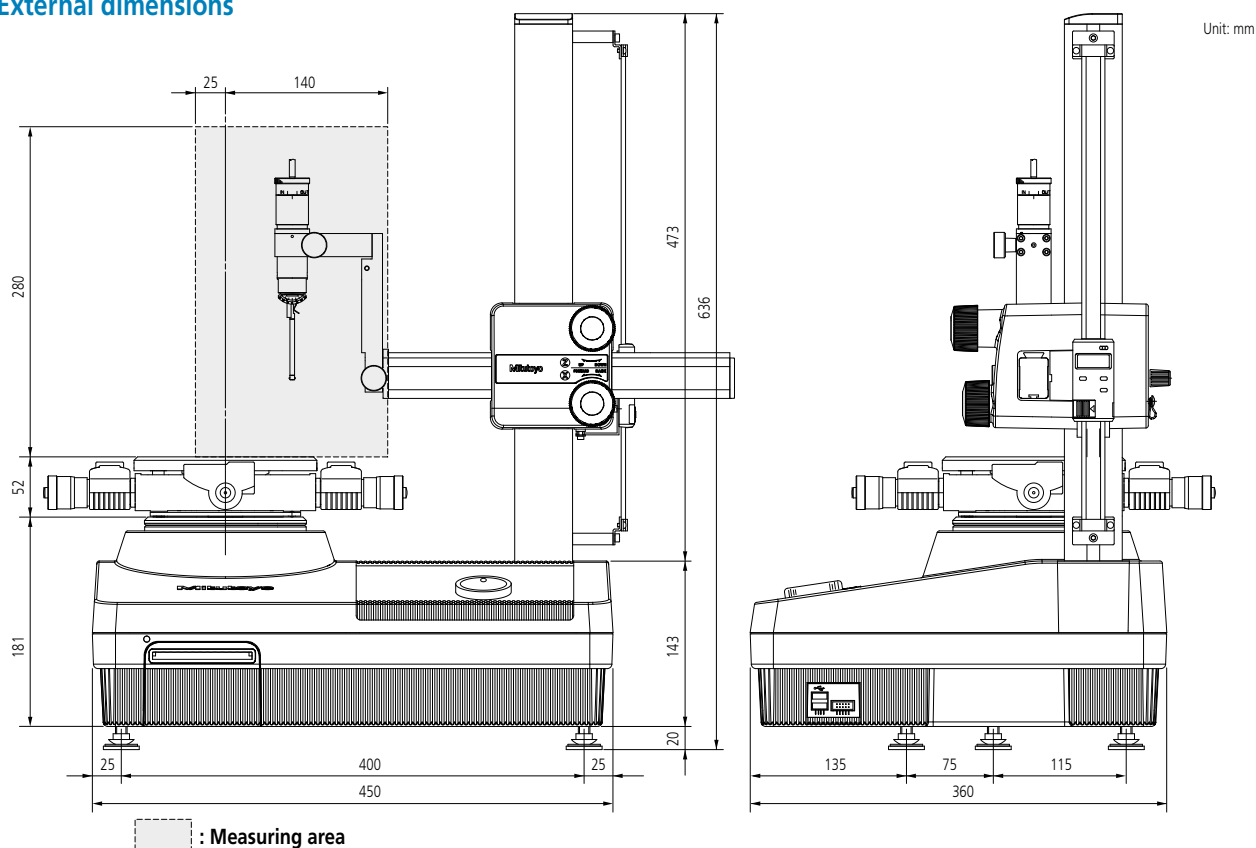

Turntable top view

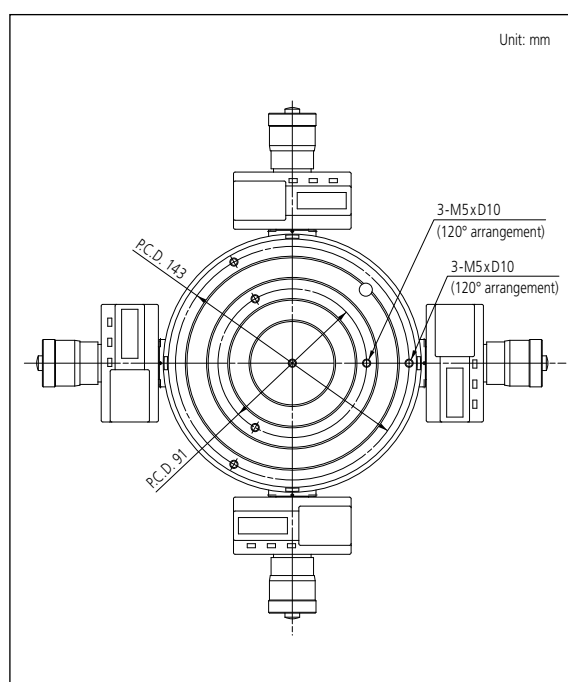

Installation floor plan

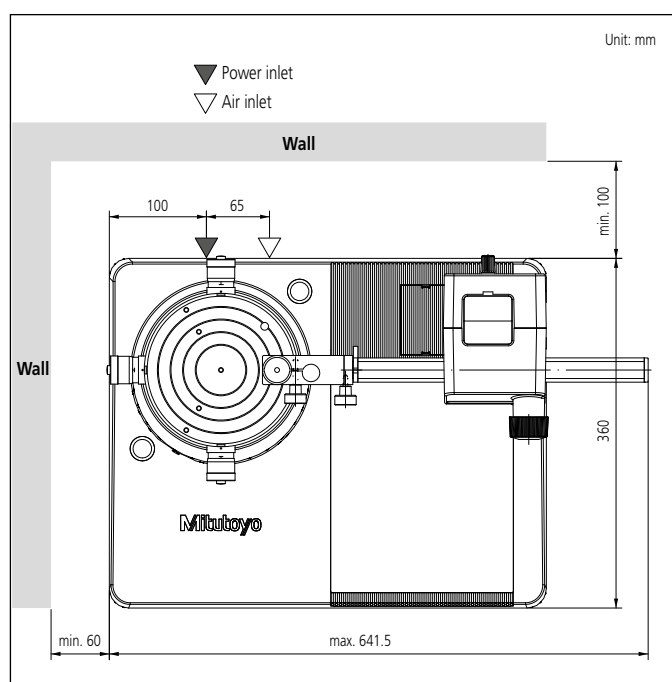

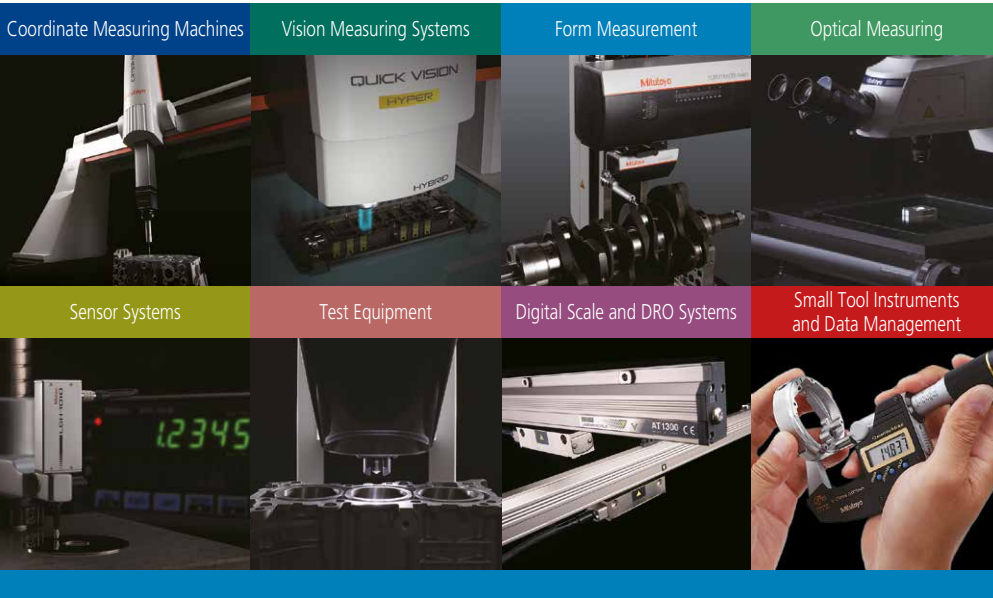

Whatever your challenges are, Mitutoyo supports you from start to finish.

Mitutoyo is not only a manufacturer of top quality measuring products but one that also offers qualified support for the lifetime of the equipment, backed up by comprehensive services that ensure your staff can make the very best use of the investment.

Apart from the basics of calibration and repair, Mitutoyo offers product and metrology training, as well as IT support for the sophisticated software used in modern measuring technology. We can also design, build, test and deliver measuring solutions and even, if deemed cost-effective, take your critical measurement challenges in-house on a sub-contract basis.

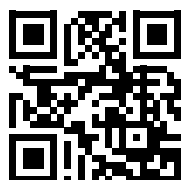

Find additional product literature and our complete catalog here.

www.mitutoyo.eu

Note: Product illustrations are without obligation. Product descriptions, in particular all technical specifications, are only binding when explicitly agreed upon. MITUTOYO and MICAT are either registered trademarks or trademarks of Mitutoyo Corp. in Japan and/or other countries/regions. Other product, company, and brand names mentioned herein are for identification purposes only and may be the trademarks of their respective holders.

Mitutoyo

Mitutoyo Europe GmbH

Borsigstraße 8-10
41469 Neuss

Tel. +49 (0) 2137-102-0

info@mitutoyo.eu

www.mitutoyo.eu