

CNC COORDINATE MEASURING MACHINES

EXPERIENCE AND INNOVATION

COORDINATE
MEASURING MACHINES



Coordinate Measuring Machines made by Mitutoyo: The boost for your products' quality!

This brochure will give you an overview of the versatile Mitutoyo range of CNC coordinate measuring technology and will show you how to focus in on the optimum solution to your specific measurement needs. Gain knowledge of all machine specifications, configurations, additional features and software solutions relevant for your measuring tasks.

Mitutoyo CNC CMMs perfectly match all your needs in terms of accuracy, throughput, reliability, flexibility and automation. Whatever your application – you will find the appropriate CMM configuration which fits your expectation. From the rough workshop environment to the ideal measuring laboratory conditions, Mitutoyo carries the perfect CNC CMM designed to perform the corresponding tasks.

The wide range of tactile or optical measuring sensors, combined with the powerful Mitutoyo software, will always provide the most suitable configuration for every measurement case.





Mitutoyo CNC CMMs – The ideal type for every need.



CRYSTA-Apex S and EX series

The Mitutoyo best-seller, offering accuracy, high scanning speed, multi-sensor compatibility and wide temperature range for an affordable price.

STRATO-Apex series

High-accuracy CMM with high-speed scanning, multi-sensor compatibility and anti-vibration stand.



LEGEX series

Ultra High Precision Premium CNC CMM: one of the world's best accuracy figures – up to 0,28 μm ! Absolute top-of-the-line technology for the most demanding requirements for precision work in the measuring laboratory.

FALCIO-Apex G series

Very large, high-accuracy Gantry construction type CMM, designed for large and heavy components' measurement. These CMMs are also compatible with multi-sensor applications.



Install your CMM directly in your production line.



MACH-3A

This horizontal spindle type CNC CMM is designed for in-line applications in your workshop environment. With its high speed index table it offers a high throughput and immediate measurement results. The small footprint saves valuable shopfloor space.

MACH-V

This vertical spindle type CNC CMM is designed for in-line applications in your production environment and perfectly suitable for conveyor loading. The workpiece can be entered into the measuring volume from any of the four sides of the machine.



MACH Ko-ga-me

This CNC measuring head is designed to be either mounted on a simple stand for standalone application, or integrated in a measuring cell. In both cases it provides high throughput and a small footprint.

CARB series

Single or dual horizontal arm type CNC CMM for car-body measurement or similar applications.



CRYSTA-Apex S: The high-performance CMM

Specially designed and constructed for European requirements, the CNC-controlled CRYSTA-Apex S is the very model of versatility and user-friendliness. With technical genius, high performance and extensive features, the CRYSTA-Apex S offers far more than conventional machines in its class. It sets a completely new standard for entry into CNC controlled 3D coordinate measuring technology.

**CRYSTA-Apex S series, moving bridge type
CNC CMM, available in 21 sizes.**

Measuring Range:

X = from 500 to 2000 mm

Y = from 400 to 4000 mm

Z = from 400 to 1600 mm

Accuracy⁽¹⁾:

From $_{EO, MPE} = 1,7 + 3L/1000 \mu\text{m}$

Repeatability⁽²⁾:

From $_{RO, MPL} = 1,3 \mu\text{m}$

Maximum driving speed:

Up to 693 mm/s

Maximum acceleration:

Up to 2309 mm/s²

Permitted temperature range:

Up to 16°C – 26°C

Maximum workpiece mass:

From 180 to 5000 kg

Remarkable features:

- New controller technology with USB interface
- Increased scanning speed of up to 100 mm/s
- Ready for multi-sensor applications:
 - Touch-trigger point probes
 - Tactile scanning probes
 - QVP image processing sensor
 - SurfaceMeasure laser sensors
 - SurfTestProbe roughness sensor
- Temperature compensation sensors for the CMM and the workpiece (2 contact sensors).



(1) According to ISO10360-2:2009, length measuring error, L = measured length in mm.

(2) According to ISO10360-2:2009, maximum permissible limit of the repeatability range

CRYSTA-Apex S

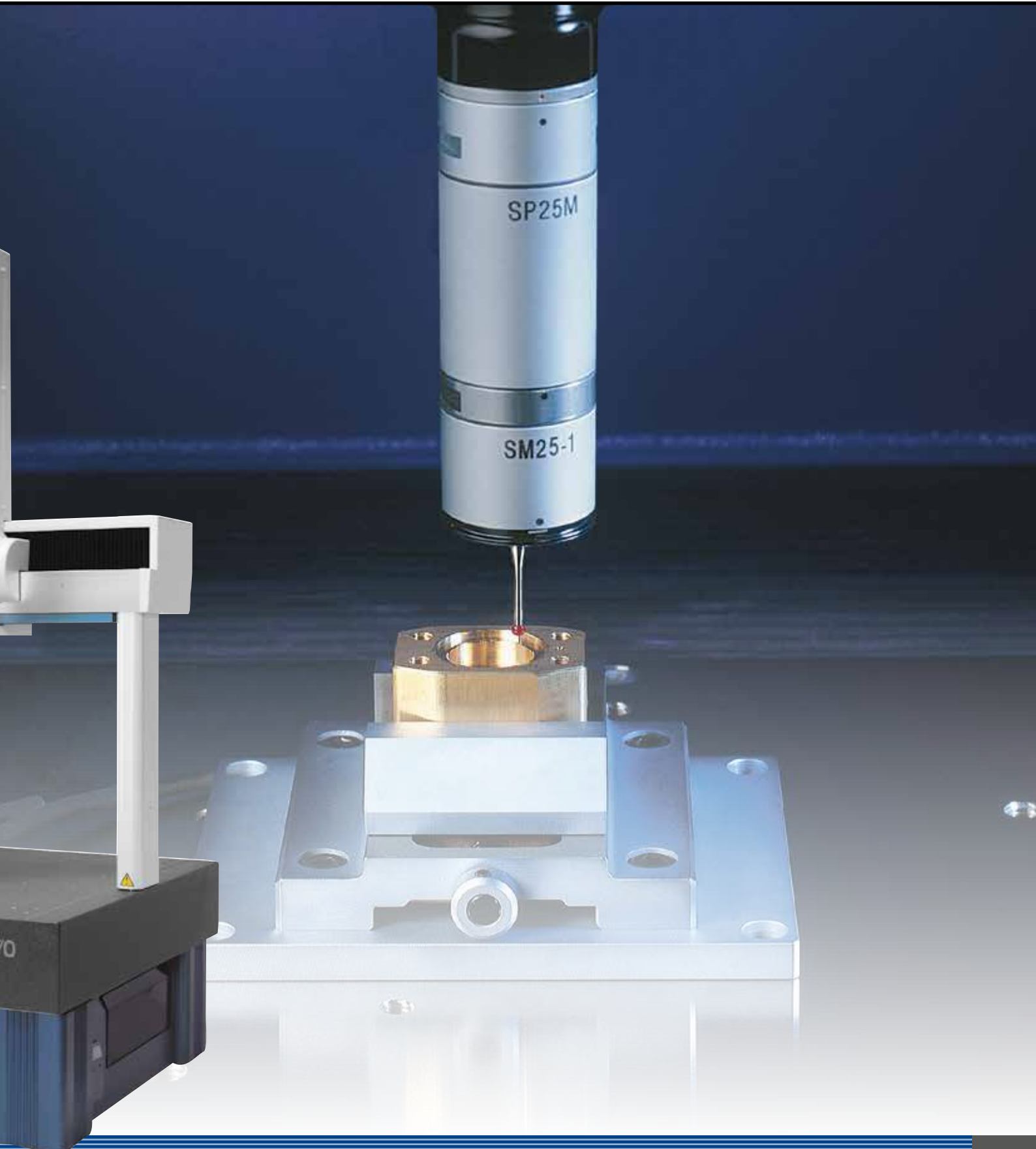

CRYSTA-Apex EX/T: 5-axis control touch-trigger PH20 probe

Based on the same CMM structure and technology as CRYSTA-Apex S series, CRYSTA-Apex EX/T series are dedicated for the PH20 probe head.

PH20's unique 'head touches' allow measurement points to be taken by moving only the head rather than the CMM structure. Using only the rapid rotary motion of the head, points can be taken faster, and with improved accuracy and repeatability. PH20's infinite positioning capability guarantees optimal feature access, minimising stylus changes.

CRYSTA-Apex EX/T series, moving bridge type CNC CMM, available in 7 sizes.

Measuring Range:

X = from 500 to 900 mm

Y = from 400 to 2000 mm

Z = from 400 to 600 mm

(other capacities on special order)

Accuracy⁽¹⁾ :

From $E_{0,1} MPE = 2,2 + 3L/1000 \mu m$

Repeatability⁽²⁾:

From $R_{0,1} MPL = 2,2 \mu m$

Maximum driving speed:

300 mm/s for each axis

Permitted temperature range:

Up to 16°C – 26°C

Maximum workpiece mass:

From 180 to 1800 kg

Remarkable features:

- 5 axis technology controller
- Repeatability – improved when 'head touch' method is used
- Accuracy – improved by using feature orientation based calibration and 'head touches'
- Infinite positioning allows any angle access
- Temperature compensations sensors



(1) According to ISO10360-2:2009, Length Measuring Error, L = measured length in mm.

(2) According to ISO10360-2:2009, maximum permissible limit of the repeatability range

CRYSTA-Apex EX/T

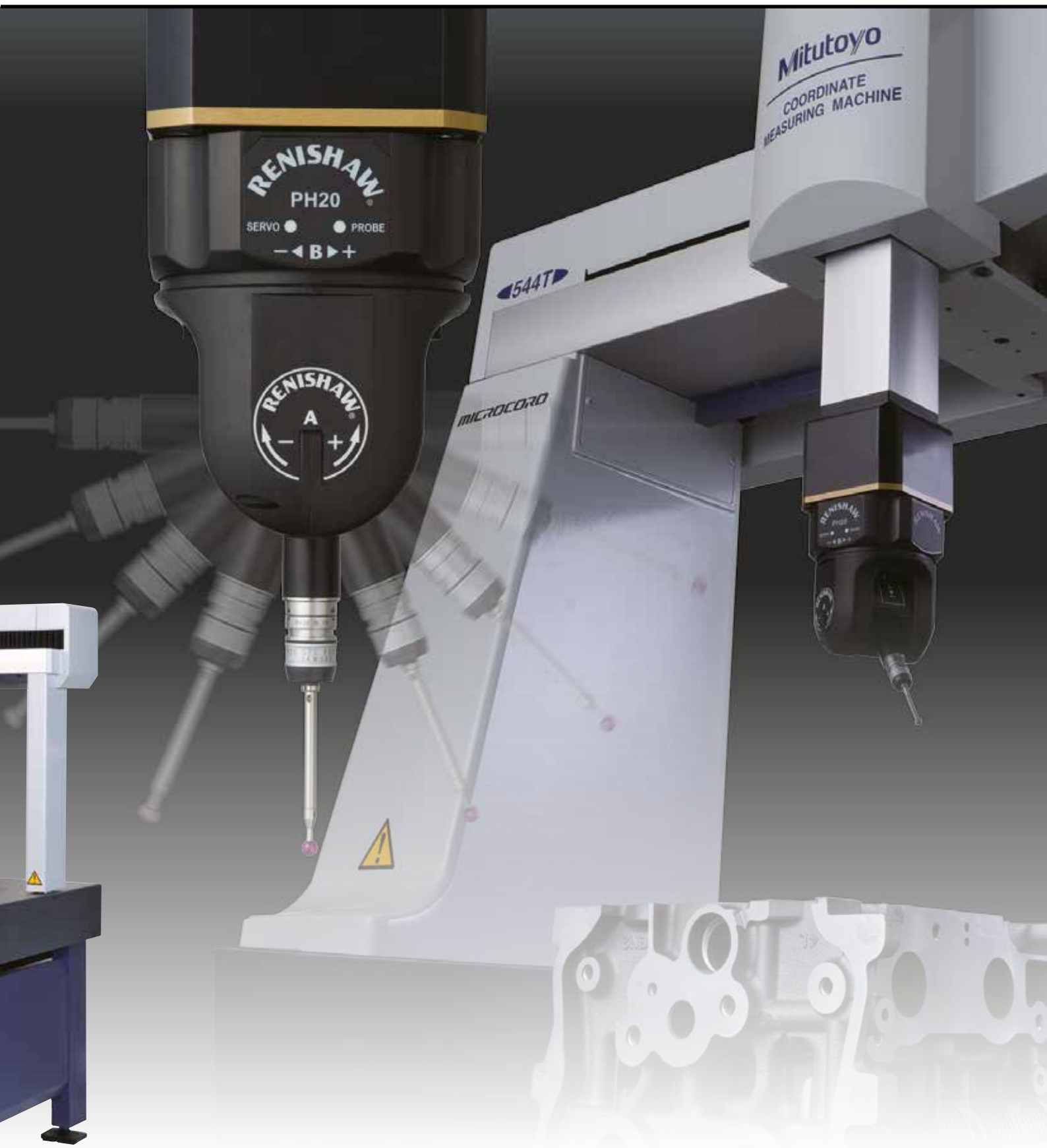

CRYSTA-APEX EX/R: 5-axis scanning with REVO probe

CRYSTA-APEX EX/R series are also based on the same CMM structure and technology as CRYSTA-APEX S series, however dedicated for the REVO probe head.

The Renishaw REVO head with Renscan5™ technology provides high speed 5 axis scanning, as well as deep hole measurement in any angle orientation. Measurement cycle time can be divided by up to 10 when using the 5 axis scanning REVO head compared with a conventional 3 axis scanning method.

Crysta-Apex EX/R series, moving bridge type CNC CMM, available in 3 sizes.

Measuring Range:

X = 1200 mm

Y = from 1200 to 3000 mm

Z = 1000 mm

(other capacities on special order)

Accuracy⁽¹⁾:

From $E_{0,1\text{ MPE}} = 2,5 + 3L/1000 \mu\text{m}$

Repeatability⁽²⁾:

From $R_{0,1\text{ MPL}} = 2,5 \mu\text{m}$

Maximum driving speed:

300 mm/s for each axis

Permitted temperature range:

Up to 16°C – 26°C

Maximum workpiece mass:

From 2000 to 3000 kg

(1) According to ISO10360-2:2009, Length Measuring Error, L = measured length in mm.

(2) According to ISO10360-2:2009, maximum permissible limit of the repeatability range

Remarkable features:

- 5 axis scanning technology controller
- Increased CMM measurement throughput
 - reduced measurement cycle time
 - high speed head and sensor calibration
- Increased CMM measurement capability
 - flexible access to features (infinite angle posture)
 - improved accuracy when the head scans without CMM movement
 - up to 500 mm stylus length
- Temperature compensation sensors



CRYSTA-APEX EX/R



STRATO-Apex: Precision meets speed.

A state-of-the-art CNC coordinate measuring machine that offers a rare blend of high-speed operation combined with highly accurate measurement. The high drive speed and acceleration guarantee top scanning performance in a machine that also offers high-accuracy measuring in the 1 µm class.

STRATO-Apex S series, moving bridge type CNC CMM, available in 9 sizes.

Measuring Range:

X = from 500 to 1600 mm

Y = from 700 to 3000 mm

Z = from 400 to 1600 mm

Accuracy⁽¹⁾:

From $EO, MPE = 0,7 + 2,5L/1000 \mu m$

Repeatability⁽²⁾:

From $RO, MPL = 0,7 \mu m$

Maximum driving speed:

Up to 606 mm/s

Maximum acceleration:

Up to 2598 mm/s²

Permitted temperature range:

Up to 18°C – 22°C

Maximum workpiece mass:

From 180 to 4000 kg

Remarkable features:

- 20 nanometer resolution scales
- Integrated anti-vibration damping stand*
- New controller technology with USB interface
- Increased scanning speed up to 100 mm/s
- Ready for multi-sensor applications:
 - Touch-trigger point probes
 - Tactile scanning probes
 - QVP image processing sensor
 - SurfaceMeasure laser sensors
 - SurfTestProbe roughness sensor
- Temperature compensation sensors for the CMM and the workpiece (2 contact sensors)

*optional on the smallest size



(1) According to ISO10360-2:2009, Length Measuring Error, L = measured length in mm.

(2) According to ISO10360-2:2009, maximum permissible limit of the repeatability range

STRATO-APEX

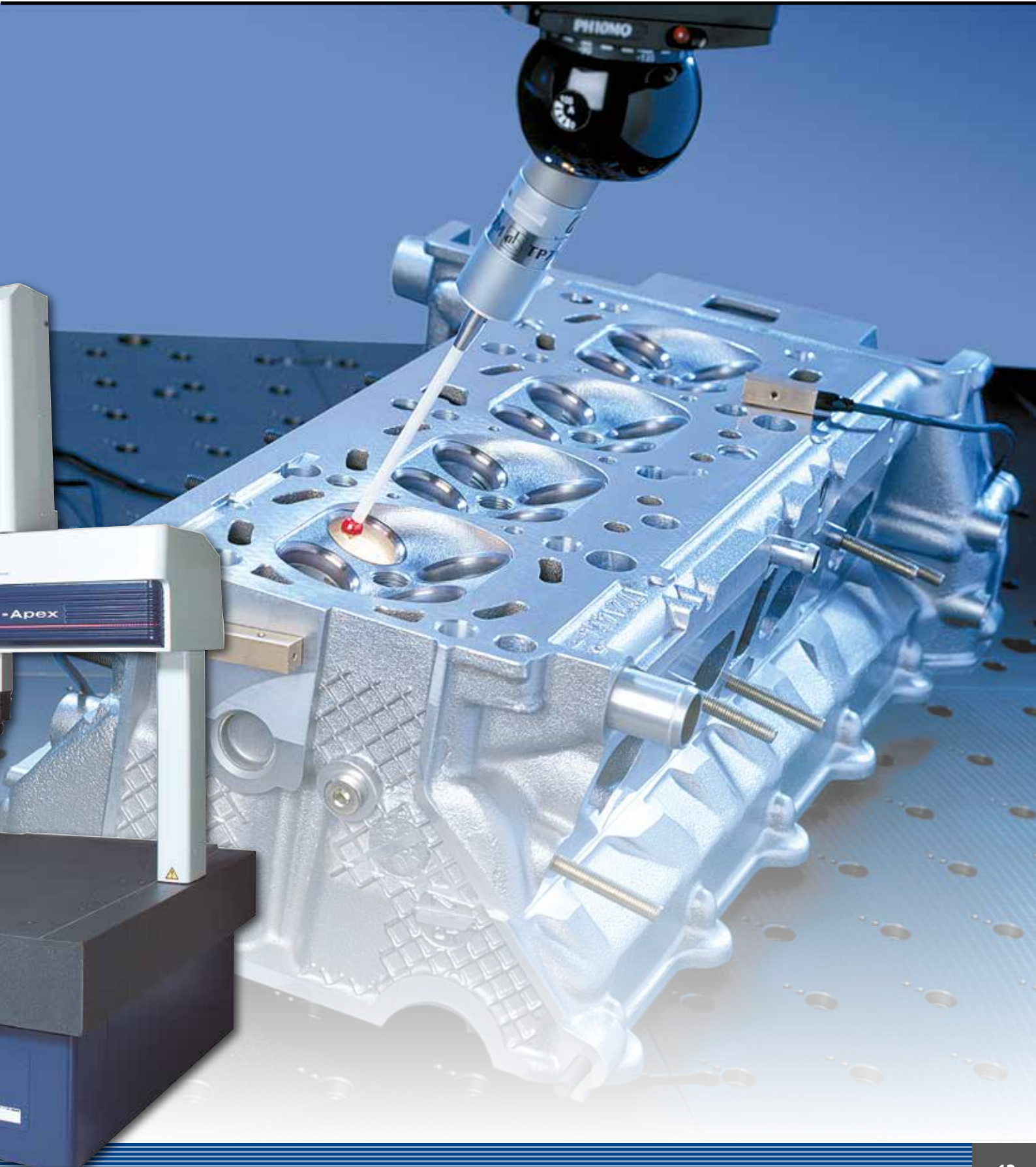

LEGEX: Ultra-high accuracy CNC coordinate measuring machine

Recognised as the world's ultimate high-precision measurement technology providing one of the world's leading measurement accuracy figures:

$$E_{0,MPE} = 0.28 + L / 1000 \mu\text{m}^{(1)}.$$

**LEGEX series, fix bridge & moving table type CNC CMM,
available in 5 sizes.**

Measuring Range:

X = from 500 to 1200* mm

Y = from 700 to 1200* mm

Z = from 450 to 1000* mm

Accuracy⁽¹⁾:

From $E_{0,MPE} = 0,28 + 2,5L/1000 \mu\text{m}$

Repeatability⁽²⁾:

From $R_{0,MPL} = 0,28 \mu\text{m}$

Maximum driving speed:

200 mm/s

Maximum acceleration:

980 mm/s²

Permitted temperature range:

Up to 18°C – 22°C

Maximum workpiece mass:

From 180 to 1000* kg

Remarkable features:

- 10 nanometer resolution
- crystallized-glass scale with virtually zero thermal expansion coefficient
- Integrated anti-vibration damping stand
- High rigidity structure made of special spheroidal graphite ductile cast iron
- Ceramic plasma spraying for each axis sliding section
- Temperature compensation sensors for the CMM and the workpiece (2 contact sensors)



(1) According to ISO10360-2:2009, Length Measuring Error, L = measured length in mm.

(2) According to ISO10360-2:2009, maximum permissible limit of the repeatability range

LEGEX

LEGEX



FALCIO-Apex G series: High-accuracy separate guide type CMM

Specially sized for highly accurate measurement of various large and precise workpieces, FALCIO-Apex nevertheless provides the performance level of a bridge type CMM.

Anchored to the floor foundations, this CMM allows almost unlimited loading mass since the workpiece is not placed on the machine structure.

FALCIO-Apex G series, moving bridge on separate guide type CNC CMM, available in 39 sizes.

Measuring Range:

X = from 2000 to 4500 mm

Y = from 3000 to 6000 mm

Z = from 1200 to 2000 mm

Accuracy⁽¹⁾:

From $_{EO, MPE} = 3,5 + 4L/1000 \mu\text{m}$

Repeatability⁽²⁾:

From $_{RO, MPL} = 3,5 \mu\text{m}$

Maximum driving speed:

Up to 500 mm/s

Maximum acceleration:

Up to 780 mm/s²

Permitted temperature range:

Up to 18°C – 22°C

Maximum workpiece mass:

Depends on floor resistance

Remarkable features:

- Ready for multi-sensor applications:
 - Touch-trigger point probes
 - Tactile scanning probes
 - QVP image processing sensor
 - SurfaceMeasure laser sensors
 - SurftestProbe roughness sensor
- Temperature compensation sensors for the CMM and the workpiece (2 contact sensors)



(1) According to ISO10360-2:2009, Length Measuring Error, L = measured length in mm.

(2) According to ISO10360-2:2009, maximum permissible limit of the repeatability range

FALCIO-Apex



MACH-3A 653: Horizontal spindle type CNC CMM for production line environment

The new MACH-3A 653 with horizontal spindle and index table is developed for in-line measurement solutions.

It achieves high throughput figures in a workshop production environment.

The small footprint saves valuable shopfloor space.

MACH-3A, horizontal spindle type CNC CMM, available in one size as standard.

Measuring Range:

X = 600 mm

Y = 500 mm

Z = 280 mm

(other capacities on special order)

Accuracy⁽¹⁾:

From $_{EO, MPE} = 2,2 + 3,5L/1000 \mu\text{m}$

Repeatability⁽²⁾:

From $_{RO, MPL} = 2,2 \mu\text{m}$

Maximum driving speed:

Up to 1212 mm/s

Maximum acceleration:

Up to 11882 mm/s²

Permitted temperature range:

Up to 5°C – 40°C

Maximum workpiece mass:

200 kg

(1) According to ISO10360-2:2009, Length Measuring Error, L = measured length in mm.

(2) According to ISO10360-2:2009, maximum permissible limit of the repeatability range

Remarkable features:

- Designed for in-line integration
- 360° access to the worktable
- Protected against rough workshop environment
- Very high speed and acceleration
- Temperature compensation up to 5 – 35°C
- Industrial cabinet to host the controller and PC
- Integrated touch screen



MACH-3A



MACH-V 9106: Vertical spindle type CNC CMM for production line environment

The MACH-V 9106 with vertical spindle is designed for in-line measurement solutions.

The architecture of MACH-V 9106 allows various types of loading accesses. Workpieces can be conveyed through the CMM either in the front/back or left/right axis.

MACH-V, vertical spindle type CNC CMM, available in 1 size.

Measuring Range:

X = 900 mm

Y = 1000 mm

Z = 600 mm

Accuracy⁽¹⁾:

From $EO, MPE = 2,5 + 3,5L/1000 \mu m$

Repeatability⁽²⁾:

From $RO, MPL = 2,5 \mu m$

Maximum driving speed:

Up to 866 mm/s

Maximum acceleration:

Up to 8660 mm/s²

Permitted temperature range:

Up to 5°C – 35°C

Maximum workpiece mass:

150 kg

Remarkable features:

- Designed for in-line integration
- 360° access to the worktable
- Protected against hostile environment
- Very high speed and acceleration
- Temperature compensation up to 5 – 35°C
- Industrial cabinet to host the controller and PC
- Integrated touch screen



(1) According to ISO10360-2:2009, Length Measuring Error, L = measured length in mm.

(2) According to ISO10360-2:2009, maximum permissible limit of the repeatability range

MACH-V



MACH Ko-ga-me: CNC CMM compact head type for production line

The MACH Ko-ga-me is designed for flexible integration in production cells, as well as for standalone applications with ultra compact footprint.

This very unique CNC probing head can be mounted on unlimited types of frames to fulfil in-line 3D measurements tasks at outstanding speed!

MACH Ko-ga-me Compact Head type CNC CMM, available in 1 size.

Measuring Range:

X = 120 mm

Y = 120 mm

Z = 80 mm

Accuracy⁽¹⁾:

From $_{EO, MPE} = 2,4 + 5,7L/1000 \mu\text{m}$

Repeatability⁽²⁾:

From $_{RO, MPL} = 1,3 \mu\text{m}$

Maximum driving speed:

Up to 340 mm/s

Maximum acceleration:

Up to 6750 mm/s²

Permitted temperature range:

Up to 10°C – 35°C

Maximum workpiece mass:

Depends on the mounting frame

Remarkable features:

- Extremely small Footprint - perfect for automated cells and stand alone solutions
- Open access to the measuring volume
- Very high speed and acceleration
- Ideal for single feature inspection and usable with scanning and point-to-point probes
- Temperature compensation up to 10 – 35°C.



(1) According to ISO10360-2:2009, Length Measuring Error, L = measured length in mm.

(2) According to ISO10360-2:2009, maximum permissible limit of the repeatability range

MACH Ko-ga-me

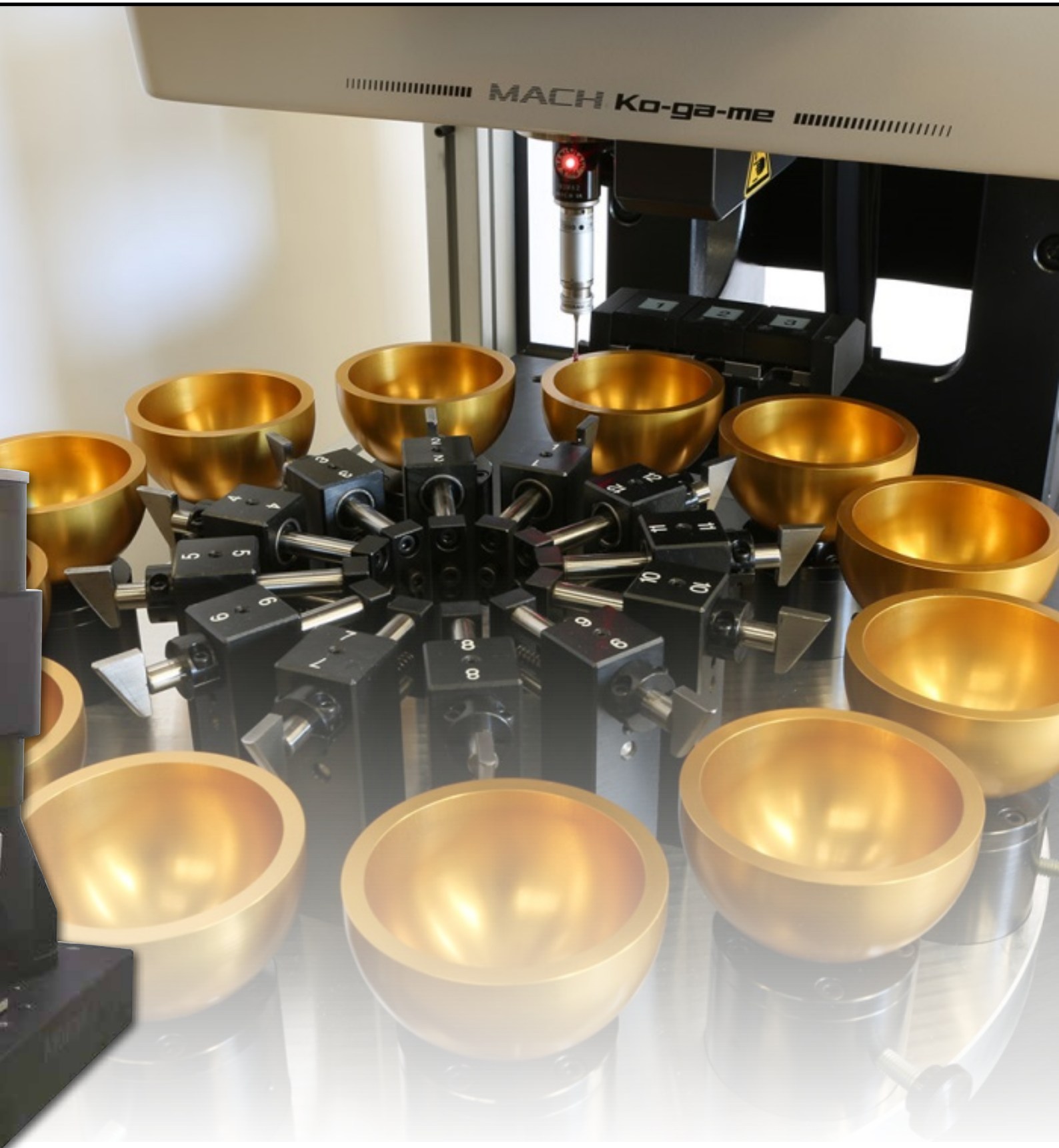

CARBapex and CARBstrato series: horizontal-arm type CNC Coordinate Measuring Machines for the car body and heavy industry applications

The Mitutoyo CARB series are divided in two accuracy classes, CARBapex and CARBstrato. Both types are available as single or dual arm types.

CARB series are designed to fit with your building requirements: these CMM can be installed either on the floor top level or integrated in your building's foundations for an easier workpiece conveying.

CARBapex and CARBstrato, horizontal arm CNC CMMs, available in 66 models (single and dual arm versions).

Measuring Range:

X = from 4000 to 8000 mm

Y = from 1400 to 1600 mm

Z = from 1800 to 3000 mm

Accuracy⁽¹⁾:

From $EO, MPE = 15+20L/1000 \leq 70 \mu m$

Repeatability⁽²⁾:

From $PFTU, MPE = 15 \mu m$

Maximum driving speed:

Up to 866 mm/s

Maximum acceleration:

Up to 2037 mm/s²

Permitted temperature range:

Up to 16°C – 26°C

(10-35°C without guaranteed accuracy)

Maximum workpiece mass:

Depends on floor resistance

(1) According to ISO10360-2:2009, Length Measuring Error, L = measured length in mm.

(2) According to ISO10360-2:2009, maximum permissible limit of the repeatability range

Remarkable features:

- Ready for multi-sensor applications:
 - Touch-trigger point probes
 - Tactile scanning probes
 - SurfaceMeasure laser sensors
- Temperature compensation sensors for the CMM and the workpiece (contact sensors)









CARB series

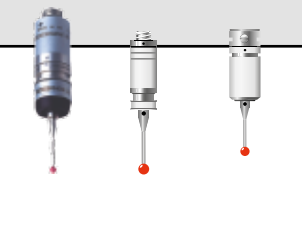

For the right touch.

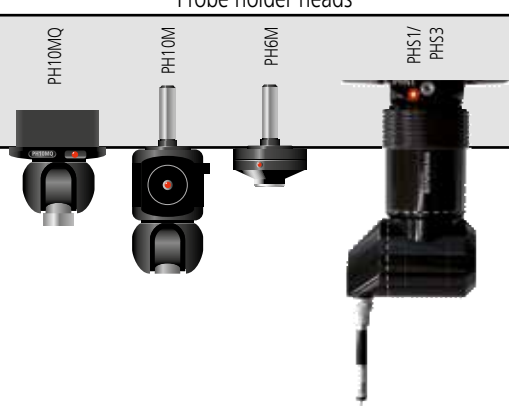
Mitutoyo offers an outstandingly wide range of contact and non-contact measuring systems for any measuring task – fixed or motorised indexing probe heads, scanning probes, optical probes, extensions and inserts – all usable in combination with efficient probe change systems. Every component carefully geared to the multiple probe capability of the Mitutoyo coordinate measuring systems.

<p>Touch-trigger probes</p> <p>TP20 TP200 TP7M</p> 	<p>Scanning probe systems</p> <p>SP-25M SP600 Q SP-80 MPP310</p> 	<p>Surface roughness probe</p> <p>Surrfest Probe</p> 	<p>Optical probes</p> <p>QVP SurfaceMeasure 606 606T 610 1010</p> 
<p>Probe holder heads</p> <p>PH10MQ PH10M PH6M PHS1/ PHS3</p> 	<p>5 axis probe heads</p> <p>PH20 REVO</p> 	<p>SM606T (3 lines) SurfaceMeasure Probe</p>  <p>SurfaceMeasure Probe series comprises non-contact laser probes to collect a 3D shape of the workpiece surface by the line laser scanning with CMM movement.</p>	

Probe change systems

<p>ACR-1</p> 	<p>MRS-ACR3</p> 	<p>SCRMP</p> 	<p>SCR200</p> 	<p>MRS-FCR25</p> 
--	---	--	--	--

Probe systems



For enhanced productivity.

Clamping and loading systems for coordinate measuring machines from all vendors.

Clamping and loading systems clearly boost the efficiency of your coordinate measuring machine. For this purpose, Mitutoyo supply the technology to simplify the clamping procedures for CMMs. Short downtimes can be realised by keeping parts available, as well as by speedily changing parts. The measurement process may be started immediately, depending on the spatially aligned positioning of the palletised test sample in the measurement volume.

The product spectrum of the modular clamping and loading technology ranges from simple, manual systems to fully automated installations.



The Mitutoyo loading system puts your components in a reproducible and spatially aligned position on the measuring table. Manufacturer-specific properties, even as individual special solutions, can easily be realised.



CMM Enclosure

In case you would need to install a standard bridge type CMM in a rough environment, Mitutoyo carry a range of industrial cabins which protect your investment from hostile atmosphere.

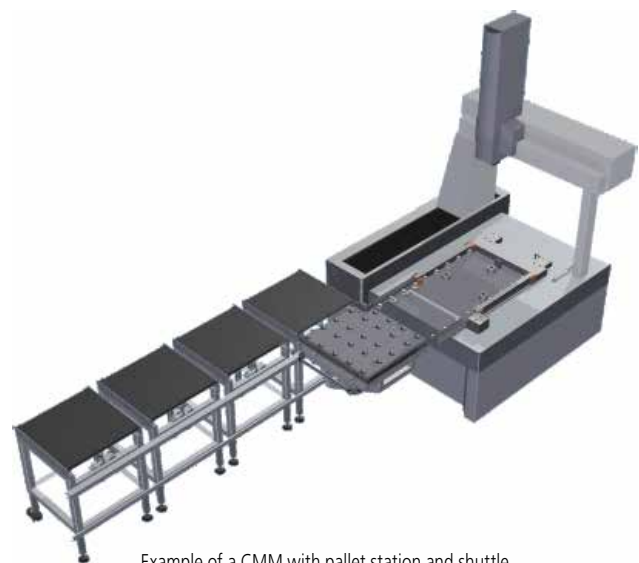

Example of a CMM with pallet station and shuttle

Options and Accessories

MRT320, a 4th axis rotary table for CNC CMM, is suitable for indexed applications and synchronous scanning measurement when using the appropriate probe head. It is provided with a rotation axis guided by an air bearing and with a high precision rotary encoder. MRT320 allows high accuracy measurement of various bodies of revolution such as gears, impellers, cylindrical cams, etc.

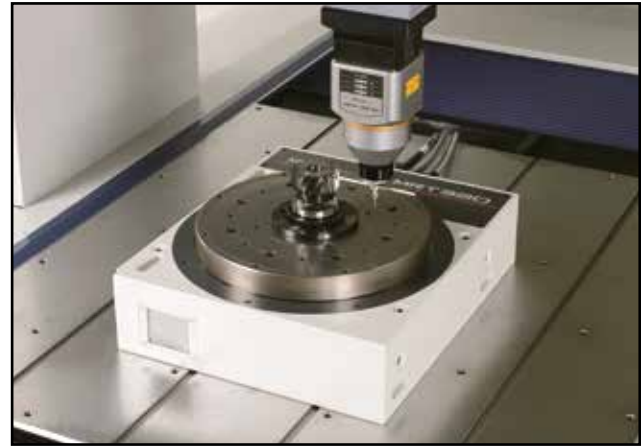
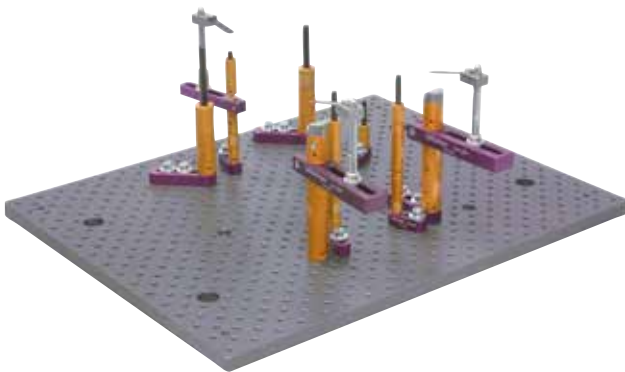

Eco-fix is an economical and flexible CMM fixture system developed in a dual aim concept:

- Affordable modular system for various different workpieces (many kits available).
- Faster and cheaper alternative to customised jigs for middle to large run sizes:
 - Save the design time and cost
 - Save the manufacturing time and cost
 - Use 1 kit for 1 part and store it for next the measurement campaign.
- Start measurement of the workpiece without any waiting time!

Which stylus is best suited, and under which conditions, for use with your measuring equipment, for your specific measuring task?

Mitutoyo offers a large choice of styli, with thorough use of materials - for the ball tip as well as the shaft - available as kits or individual selection.

Whatever the probe thread, you will find the corresponding styli series suitable for your application.



MiCAT Planner: Automatic measurement program generation

Programming in a conventional way can result in misinterpretation of design intent. Complex measurement programs require path optimisation in order to avoid a waste of time. Plus, the work of different programmers can result in discrepancies.

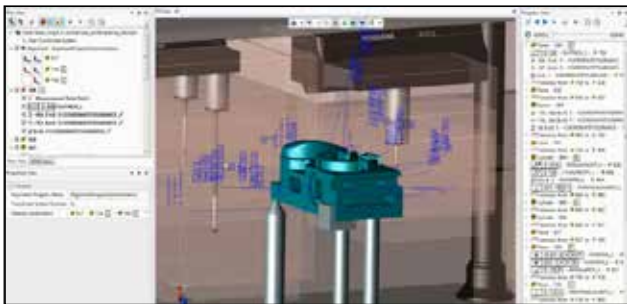
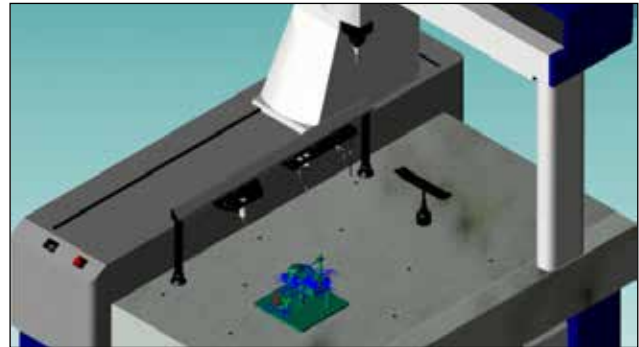

The Mitutoyo CMM programming software MiCAT Planner meets all these demands. Directly reading the GD&T contained in PMI data of the workpiece CAD file, MiCAT Planner automatically generates the best free collision measurement program taking your measurement rules into account.

MeasurLink – Data Collection

Collecting, archiving and analysing the measured data is the main goal of any metrology – related task!

MeasurLink provides you a complete suite of SPC modules matching your company organisation and network.

From a simple data acquisition module to the professional process analyser, a full range of fix or floating licenses is available.

The dedicated module for Gage Management offers you the possibility to monitor the usage of your measuring tools and calibration status.

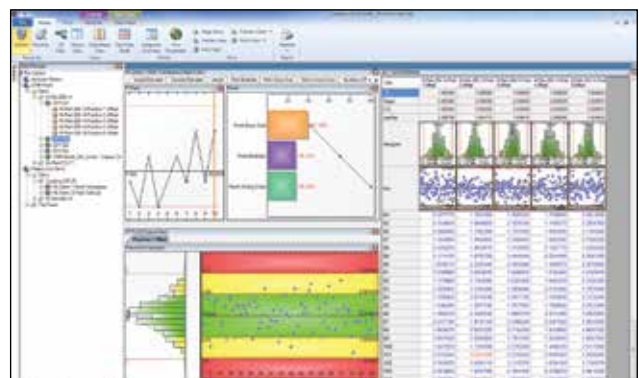
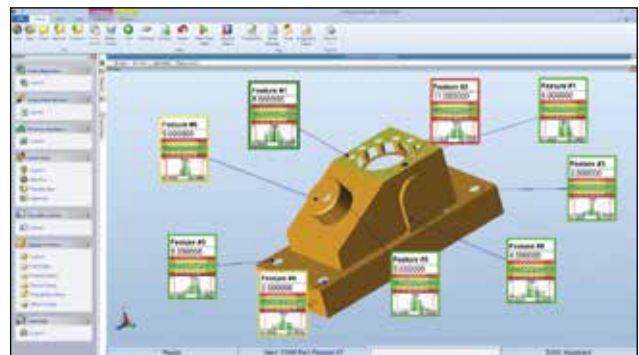

Software

MCOSMOS – The modular software for all kinds of measurement is the core of CMM software:

- Organise your measurement programs on the network, add pictures of workpiece and fixture positions
- Add commands and instructions to guide the operator
- Create individual reports meeting your customers' needs
- Archive your results in formats like pdf, xls, HTML and many others
- SPC with MeasurLink or export to QS-Stat or CAQ-systems like Böhme & Weihs
- Export of geometric elements to CAD systems
- Revision Management for authorised usage of validated part programs as standard
- Meet the requirements of FDA title 21 CFR Part 11 without extra costs.

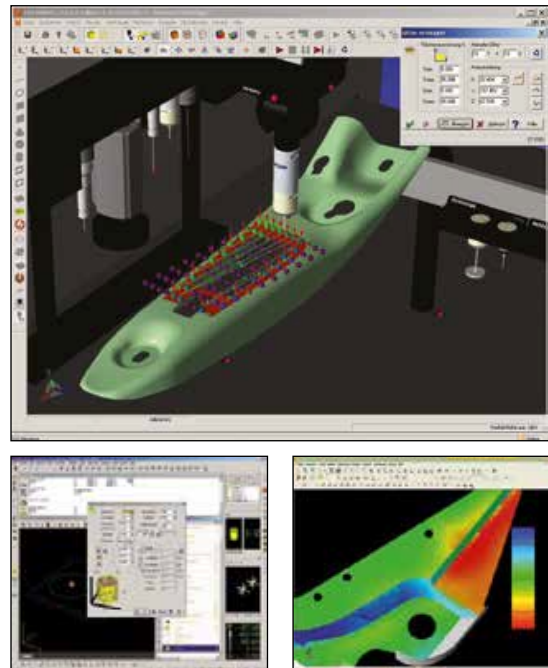

Mitutoyo offers the following packages:

MCOSMOS-1:	The basic software package for prismatic workpieces Easy programming of geometrical elements by joystick control or input of nominal values. Special features like clearance height or automatic element recognition helps you prevent collisions and reduce programming time.
MCOSMOS-2:	The CAD package for freeform surfaces and geometric elements Why manually enter parameters when all features are already available in the CAD model? CAD based programming offers you a way to cut down the programming time even more. GD&T entities inside the CAD file helps you to measure all essential features.
MCOSMOS-3:	The full package MCOSMOS-3 provides additional tools for measurement evaluation of contours in 2D or on the CAD model.
MCOSMOS Offline:	All three packages are available in offline versions. Programming in offline mode keeps the CMM free for real measurements. Since you only need the CAD file for programming, you don't even have to wait for the first part being produced. Many CAD interfaces like CATIA or PRO/E are available that enable you to import your CAD models without any data getting lost. VIRTUAL MCOSMOS-2 can be ordered as a multi-license package for 1, 5 and 10 users.
Virtual MCOSMOS	This module is dedicated for measuring uncertainties' evaluation. Taking into account the actual probing strategy, the CMM calibration data and real environment conditions, Virtual CMM is capable of expressing the possible range of uncertainty for each feature measured.

Many other optional modules are available for your dedicated applications, like measurement of gears, airfoils, blisks, or for part-program conversion into DMIS format.



**Whatever your challenges are,
Mitutoyo supports you from start to finish.**

Mitutoyo is not only a manufacturer of top quality measuring products but one that also offers qualified support for the lifetime of the equipment, backed up by comprehensive services that ensure your staff can make the very best use of the investment.

Apart from the basics of calibration and repair, Mitutoyo offers product and metrology training, as well as IT support for the sophisticated software used in modern measuring technology. We can also design, build, test and deliver bespoke measuring solutions and even, if deemed cost-effective, take your critical measurement challenges in-house on a sub-contract basis.

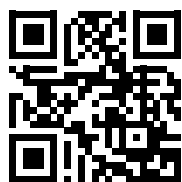

**Find additional product literature
and our product catalogue**

www.mitutoyo.eu

Note: All information regarding our products, and in particular the illustrations, drawings, dimensional and performance data contained in this printed matter as well as other technical data are to be regarded as approximate average values. We therefore reserve the right to make changes to the corresponding designs, dimensions and weights. The stated standards, similar technical regulations, descriptions and illustrations of the products were valid at the time of printing. In addition, the latest applicable version of our General Trading Conditions will apply. Only quotations submitted by ourselves may be regarded as definitive.

Mitutoyo

Mitutoyo Europe GmbH

Borsigstraße 8-10
41469 Neuss

Tel. +49 (0) 2137-102-0
Fax +49 (0) 2137-102-351

info@mitutoyo.eu
www.mitutoyo.eu