

QUICK IMAGE SERIES

2-D COLOR VISION MEASURING SYSTEM

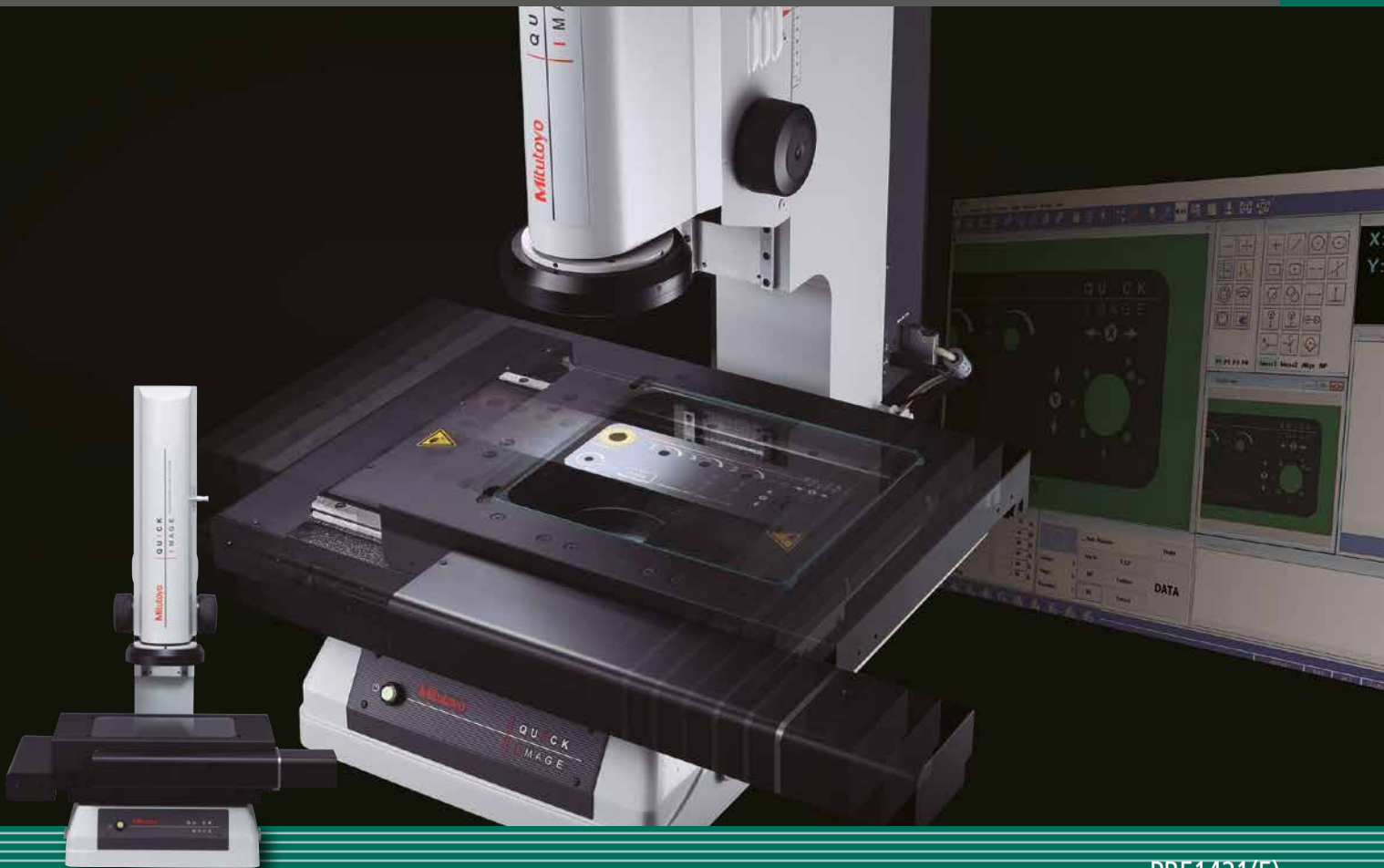

Powerful backup for your
quality control system

Simple to operate and
easy-to-perform
measurement

Reliability

Usability

Efficiency

Outstanding improvement
in operational efficiency
and productivity





Powerful backup for your quality control system

Lets you perform stable and highly accurate measurements regardless of the position within the field of view

The highest level of measuring accuracy within the screen in its class Patent registered (Japan)

- Accuracy of $\pm 1,5 \mu\text{m}$ within the screen, repeatability of $\pm 0,7 \mu\text{m}$ in high-resolution mode (QI-B Series) and a large focus depth.

Both a wide field of view and high accuracy

- Sub-pixel processing enables high-accuracy edge detection.

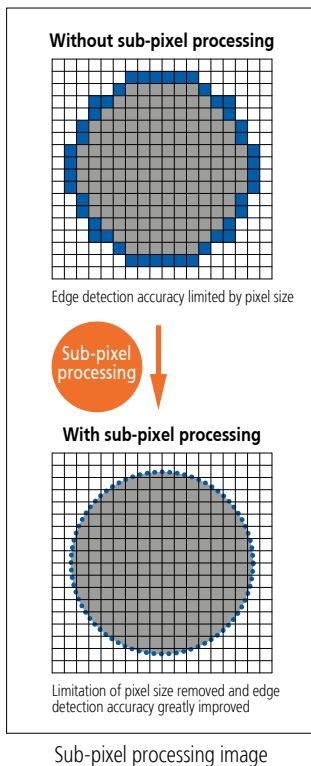

Stable and highly accurate measurement of large workpieces

Highly accurate stages

- Stages come in various sizes with an accuracy of $\pm (3,5 + 0,02 L) \mu\text{m}$, letting you perform highly accurate and stable measurements, and obtain reliable data for any kind of workpiece.

Rigid construction

- Robust construction with a maximum load capacity of 20 kg and a vertical stroke of 100 mm allow large workpieces to be measured.

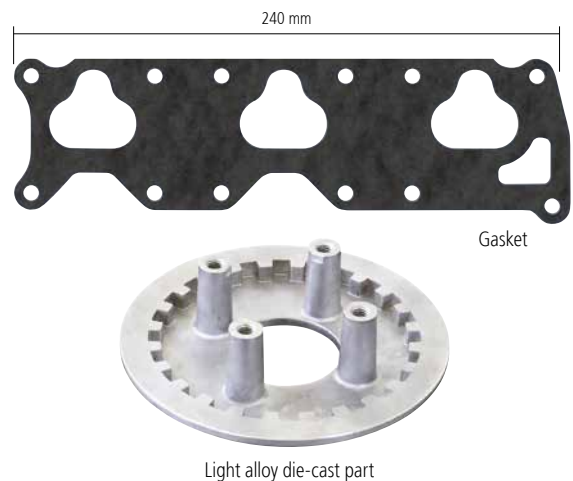

Ultra-long working distance of 90 mm

- The 90 mm working distance ensures that you can focus, even with stepped workpieces, without worrying about collisions.

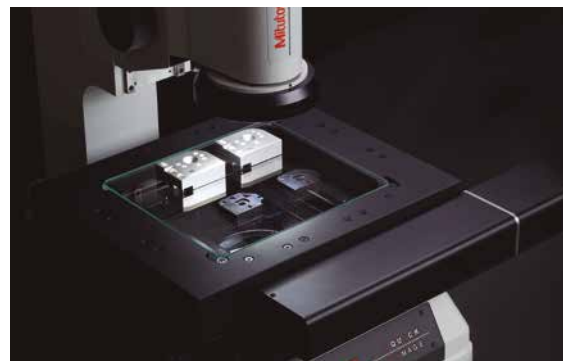

Human errors due to focusing eliminated

Utilizes our in-house developed Telecentric Optical System Patent registered (Japan, the U.S.A. and Europe)

- Errors due to height within a depth of focus with steps of up to 22 mm are strictly minimized. Measurements, in which human errors due to focusing are eliminated, are possible.

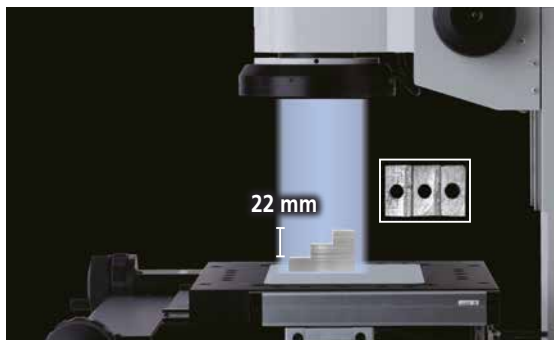

Measuring a stepped workpiece

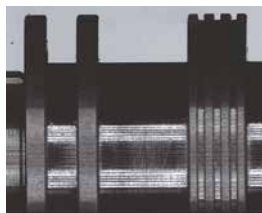

Measuring of a cylindrical workpiece

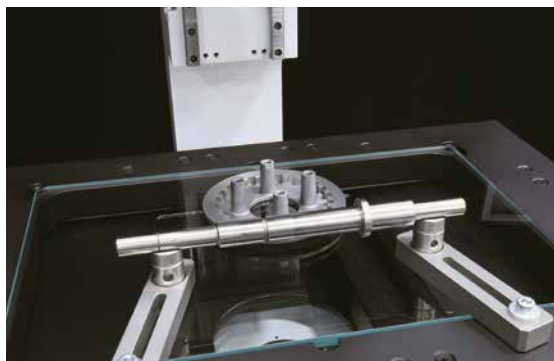

Outstanding sense of security - traceability to national standards

Mitutoyo...

Uses calibration artifacts traceable to national standards

- Mitutoyo has a large collection of standard artifacts whose dimensions are traceable to the national length standards in Japan. These artifacts are used to calibrate the specialized equipment used in the calibration of Mitutoyo's measuring tools and instruments, and so traceability to international length standards is established and maintained. Mitutoyo also provides the service of temperature calibration that is absolutely essential to high-accuracy length measurement.

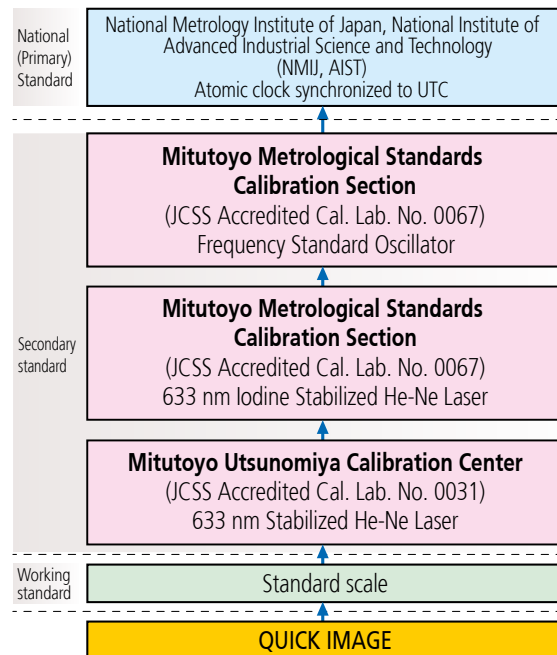

*This chart shows a simplified traceability system of QUICK IMAGE.



Simple to operate and easy-to-perform measurement



Entire view of a large workpiece drastically improves ease of operation and measurement efficiency

Stitching function

- The newly-developed correction algorithm for use in stitching (multiple image-to-image coupling) achieves high-accuracy measurement. The stitching function enables a large workpiece that extends beyond the visual field to be measured with its entire image displayed. This allows quick identification of measured and unmeasured points at a glance.
- After a stitching operation, measurement is speedily advanced without the need to move the stage.

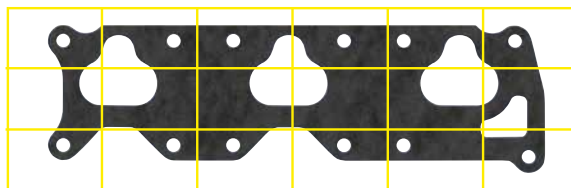

Multiple field of view stitching image

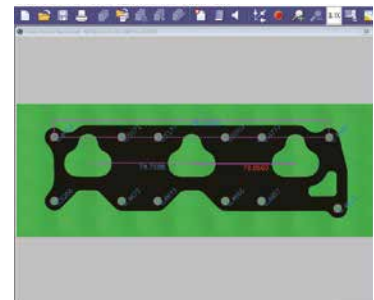

Prompt measurement with the entire workpiece image on screen

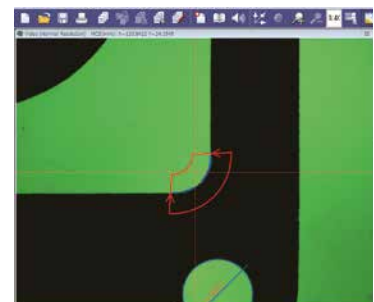

Correct measurement of a small feature is enabled by zooming in.

Simple execution of multiple measurements

One-click tool

- With just one click, anyone can easily perform multiple measurements.
- The outlier removal function automatically eliminates abnormal measurement points, such as dust or burrs, thus enabling accurate and reliable multipoint measurement.

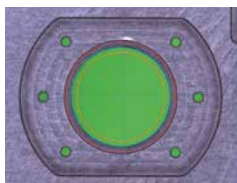

One-click circle tool

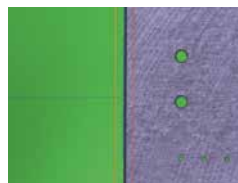

One-click box tool

Easy-to-operate without manual

EZ mode Design application pending (Japan)

- This mode provides an operation guidance display to guide the operator, even if it is their first time performing measurements, so there is no need to keep referring to the instruction manual while working.

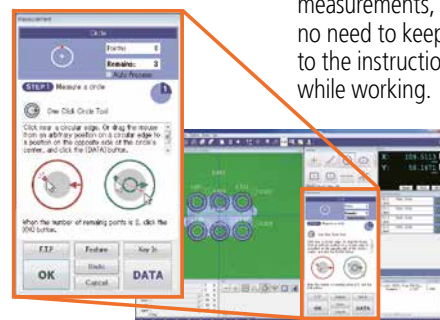

No troublesome positioning required

One-click execution function Patent pending (Japan)

- After placing a workpiece within the field of view, the machine automatically recognizes its position and angle using a pattern search function and then finishes the measurements.
- There is no need for positioning and axially-aligning the workpiece.

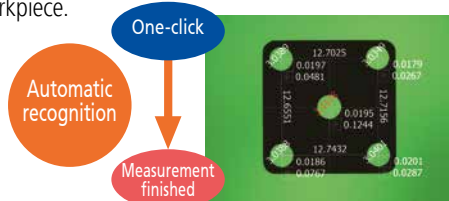

The position and inclination of a workpiece can be measured even if it has moved.

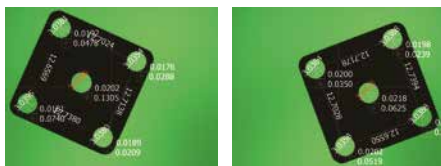

An intuitive OK/NG judgment of measurement possible

Template comparison test function

- Use the function to compare workpieces against their templates to enable OK/NG judgments to be made at a glance.
- The function lets you utilize any drawing and CAD model for templates, with the exception of standard templates.



Enhanced rectangle template



User template

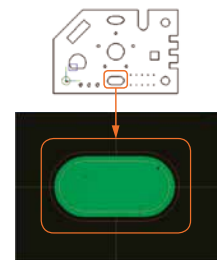

CAD user template
Note: QS-CAD I/F is required (available as an option).

Simple focusing

Wide focus range

- Our specifically designed optical system achieves a long focal depth of 22 mm. This allows efficient measurement virtually without time-consuming, focusing task.

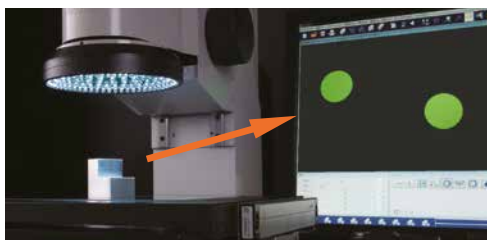

Focusing in on a workpiece like the one shown above is unnecessary.

Capable of visually capturing an entire image

Graphics function

- The current position, coordinate system, measuring item and measurement result are automatically displayed in a graphics window. The graphics window prevents omissions and measurement errors from occurring.
- 2-D CAD model data can be imported (optional) in order to better capture the actual full image.

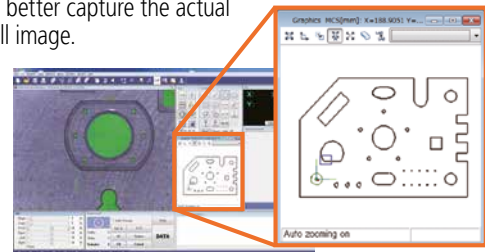

Perform quick measurements even on large workpieces

Quick release mechanism on the XY stage *QI-A series, QI-B series

- Quick release mechanisms are built into both fine feed controls on the XY stage.
- This allows the stage to be moved rapidly to bring the next measuring point into view no matter where it is on the workpiece.

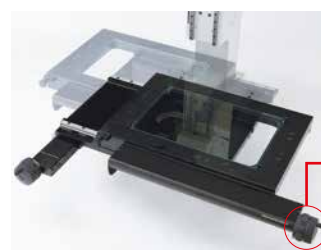

Quick-release ring



Outstanding improvement in operation efficiency and productivity



User-friendly and convenient XY stage movement

New lineup of motor-driven stage models *QI-C series

- The joystick provides an easy, convenient control for coarse and fine feed of the stage.
- This effortlessly moving XY stage demonstrates outstanding performance in full-length measurement.
- The motor-driven stage automatically moves for stitching by only specifying its start and end points.



Dedicated remote box



Motor-driven stage

Confirm measurement results quickly and easily

Video window measurement result display function

- Measurement results can be understood intuitively just by looking at a measurement image. Any out-of-tolerance result data is easily identified by changing its display color.
- A graphic image with measurement data also leads to creation of a user-friendly report.
- Each OK/NG result is color-coded with its display color freely selectable.

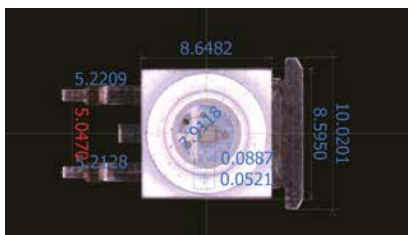

The measurement results display for OK/NG can be color-coded to meet your requirements.

Capable of supporting a variety of workpieces

Large stage model and extensive lineup of stages

- The large stage allows you to arrange multiple workpieces and measure them in a single setup, thereby, saving valuable time that would otherwise be spent in loading and unloading the stage.
- XY measurement range: workpieces up to 400 x 200 mm
- 100 mm Z-stroke allows you to measure tall workpieces.
- A maximum load capacity of 20 kg allows you to measure heavy workpieces.

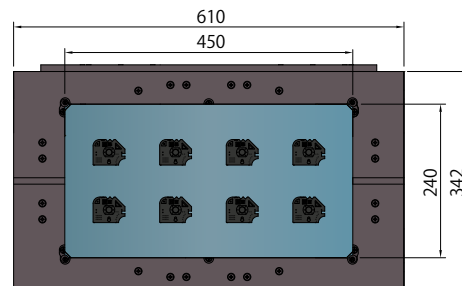

Take advantage of the large stage by performing multiple measurements with one setup.

Measure multiple workpieces, within one field of view, all at once

Locate and measure multiple workpieces with just one click

- Use pattern search function for multiple workpieces within one field of view and measure them all with one-click. This eliminates the need for accurate positioning of workpieces and cumbersome setup of fixtures.

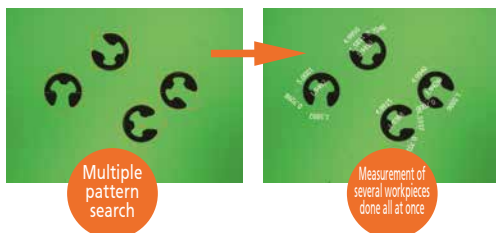

Simple "OK/NG judgment" of multiple workpieces

Tolerance judgment result display function

- For faster operation, OK/NG judgment can be seen at a glance.
- OK/NG judgment can be done for each measurement item and judgment can be passed on each workpiece.
- Prevents NG data omissions.

Tolerancing Result		
No. 1	001.jp	
ID: 1	Feat.: Circle	OK
Label:		
ID: 2	Feat.: Circle	OK
Label:		
ID: 3	Feat.: Circle	OK
Label:		
ID: 4	Feat.: Circle	OK
Label:		
ID: 5	Feat.: Circle	OK
Label:		
ID: 6	Feat.: Circle	OK
Label:		
ID: 7	Feat.: Circle	OK
Label:		
OK		

Generate reports and observe – all with one machine

High-definition color camera

- This camera provides high-resolution color images for effective use in high-accuracy measurement and workpiece surface observation.
- Bright color measurement images are easily stored as a file and can be used for creating an easy to understand measurement report.



Simple execution of measurement procedure programs

Program launcher

- An automatic measurement procedure program can be stored under a dedicated icon along with a photo and comments to enable the required programs to be started easily.
- 10 icons are available and programs can be managed for each operator or workpiece.



Program launcher icons



Automatic measurement procedure program storage window

High-accuracy measurement with bright and clear images

Wide field of view / high-resolution mode

- The high-resolution mode produces the same wide field of view as the normal mode that operates with a deep focal depth and can therefore share a single measurement procedure so that seamless measurements can be executed.
- The shallow depth of focus in high-resolution mode shows the edges of stepped workpieces more clearly, making measurements highly accurate.

Enhanced illumination Patent registered (Japan)

- The enhanced illumination function of the high-resolution mode enables measurements of low reflectivity workpieces, like rubber and black resin moldings, to be performed with a clear image.

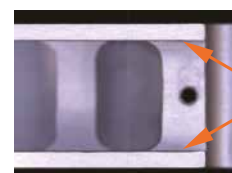

Edge measurement of a stepped workpiece (high resolution mode)



Surface observation of black rubber

Measurement examples

Progressive die-pressed parts

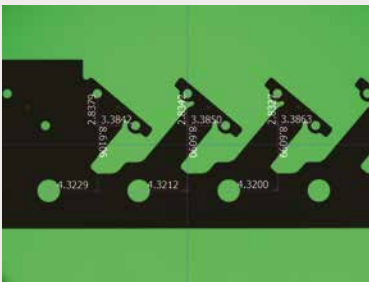

Measure a diameter and position of each hole.

O-ring

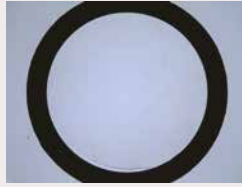

Enhanced illumination is very effective for low reflectivity materials such as rubber and black resin. (Use ring illumination in high-resolution mode + enhanced illumination.)

Weatherstrip



Execute a pattern search unrelated to position and finish measuring in one click.

Measuring a tiny stepped workpiece

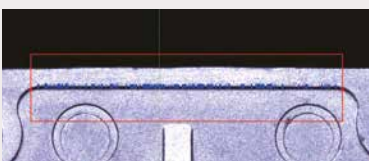

You can see and measure edges easily with just one quadrant of the ring light providing illumination.

Measuring a stepped workpiece



Measure with simple focusing.

Switch sheet measurement



The color camera allows enhanced observation and measurement of workpieces. It is best suited for inspection of printed material and creation of a report.

Standard software QIPAK

QIPAK (two modes) enables quick and easy measurement

EZ mode
(Simple measurement mode)



PRO mode
(General purpose measurement mode)

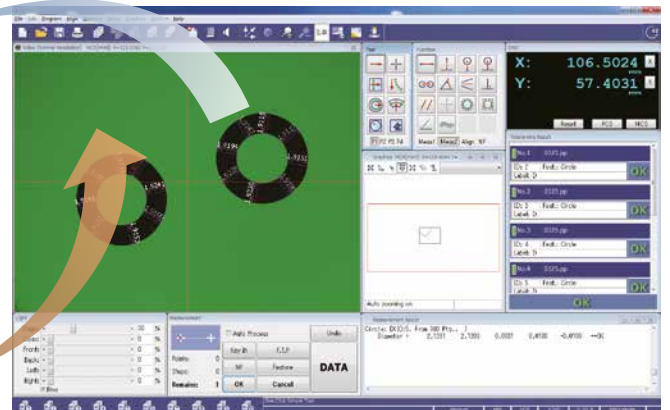
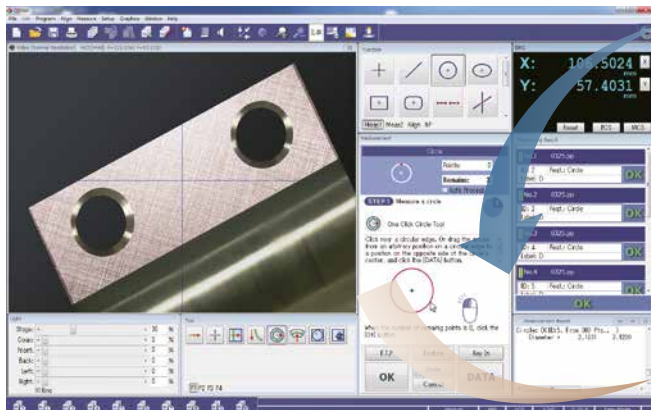

Simple execution and editing of programs

Smart editor

This function allows XY-stage target position, illumination condition, etc., to be separately displayed as icons or labels in the list of part programs (automatic measurement procedure programs), thereby simplifying program editing.

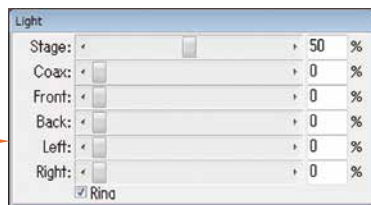
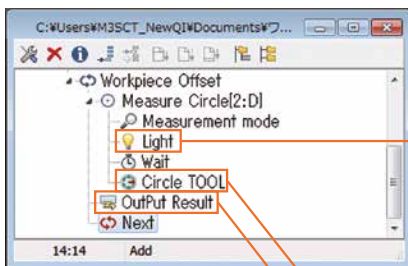

Editing an illumination condition according to the dialog



Editing a circle tool within the video window

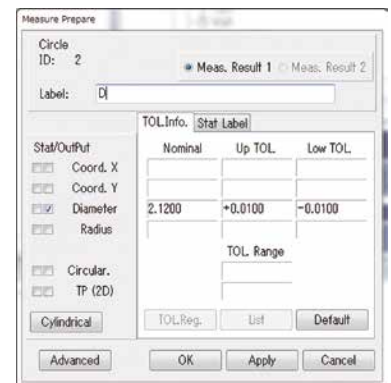

Editing design values and tolerances according to the dialog

Powerful edge detection functionality enables fast measurement

Outlier removal

Removes outliers caused by anomalies such as debris, burrs and chips.

Auto trace tool

Automatically detects the edges of unknown contours and obtains point group data. Point group data lets you perform contour form analysis and design value comparison using FORMTRACEPAK-AP (optional).

Dual-area contrast tool

Automatically sets the amount of illumination so that the contrast between two regions is maximized. Users can also set the optimum intensity to suit the workpiece.

Optional application software and accessories

Easily handle sophisticated dimension and contour evaluations

Contour evaluation and analysis software: FORMTRACEPAK-AP

Data processing software for advanced form analysis that carefully reads point group data acquired via tools such as the auto trace tool.

- A contour measurement is easy to make.
- Perform contour matching against design value data.
- You can define virtual circles of a given diameter enabling over-pin diameter analysis to be performed.

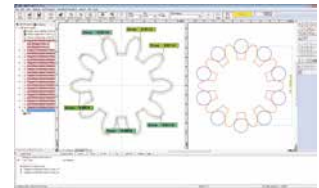

Example of gear contour matching and an over-pin diameter analysis

Effective use of CAD model

Measurement support software: QS-CAD I/F

2-D CAD model data (DXF-, or IGES-formatted) can be imported into QIPAK. Conversely, QIPAK measurement results can be converted into 2-D CAD model data. The design value for each measurement item is automatically entered. Since the graphics window makes the present location easy to identify, operator can quickly move the stage to a given point in the 2D CAD model.

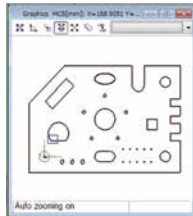

Early detection of process irregularities

Centralized process management software: MeasurLink

Statistical data can be displayed in real-time, making early detection of process irregularities possible. Early identification of an out-of-control situation enables rapid remedial action to be taken when necessary.

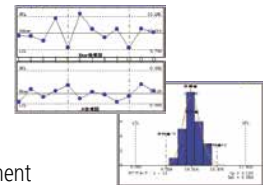

Examples of remedial action

- Mold repair or cycle-timing change
- Cutting tool adjustment or replacement

Holder with clamp

Clamping of thin workpieces such as PCBs and pressed parts

Order No.: **176-107**

Maximum clamp length: 35 mm
Dimensions: 62 (H) x 152 (W) x 38 (D) mm
Mass: 0,4 kg

Note: An adapter set is required.



V-block with clamp

Clamping of cylindrical objects

Order No.: **172-378**

Max. supportable diameter: \varnothing 25 mm
Center height from mounting face: 38-48 mm
Dimensions: 117 (H) x 90 (W) x 45 (D) mm
Mass: 0,8 kg

Note: An adapter set is required.



Swivel center support

Clamping of a workpiece between centers for effective thread diameter and depth measurements

Order No.: **172-197**

Can be set to an inclination angle of $\pm 10^\circ$, in minimum increments of 1°
Max. supportable dimensions:
• When horizontally positioned: \varnothing 80 x 140 mm
• When tilted at 10° angle: \varnothing 65 x 140 mm
Mass: 2,5 kg

Note: An adapter set is required.



Stage adapter sets

These are used when connecting some optional peripherals to the measuring device.



Order No.: **Stage adapter: 176-304**
Stage adapter B: 176-310

Dimensions (1 piece): 50 (W) x 340 (D) x 15 (H) mm
Note: The stage adapter B is 280 (D).
Mass: Stage adapter: 1,5 kg
Stage adapter B: 1,2 kg

	Stage size	
	1010 2010	2017 3017 4020
176-304 Stage adapter	—	□
176-310 Stage adapter B	□	—

Note: One set consists of two adapters.

Table

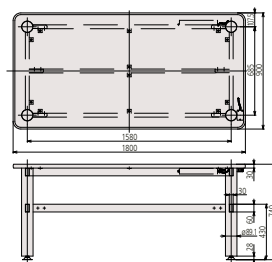

Order No.: **02ATE760**

Dimensions: 1800 (W) x 900 (D) x 740 (H) mm
Mass: 60 kg

Foot switch

Quick data entry while gripping the handle



Standard type
Order No.: **937179T**

Rigid type
Order No.: **12AAJ088**

Optional accessories

Ring light diffusion plate

Order No.: **02ATX180**

Effective on a diffusely reflective workpiece such as a machined surface. This plate makes the surface appear smooth to obtain an image suited for measurement. The working distance is 76 mm.



Mounting stand

Order No.: **02ATX190**



Dedicated to the QI main unit
This stand allows increased freedom of system layout by separating the main unit from the PC.

Specifications

		Manual stage model					Motorized stage model		
0.2X	Model	QI-A1010D	QI-A2010D	QI-A2017D	QI-A3017D	QI-A4020D	QI-C2010D	QI-C2017D	QI-C3017D
0.5X	Model	QI-B1010D	QI-B2010D	QI-B2017D	QI-B3017D	QI-B4020D			
Measuring range (XxY)		100x100 mm	200x100 mm	200x170 mm	300x170 mm	400x200 mm	200x100 mm	200x170 mm	300x170 mm
Effective stage glass size		170x170 mm	242x140 mm	260x230 mm	360x230 mm	440x232 mm	242x140 mm	260x230 mm	360x230 mm
Maximum stage loading *1		Approx. 10 kg		Approx. 20 kg		Approx. 15 kg	Approx. 10 kg	Approx. 20 kg	
Main unit mass		Approx. 65 kg	Approx. 69 kg	Approx. 150 kg	Approx. 158 kg	Approx. 164 kg	Approx. 72 kg	Approx. 153 kg	Approx. 161 kg

*1 Does not include extremely offset or concentrated loads

		QI-A / QI-C		QI-B	
FOV		32 x 24 mm		12,8 x 9,6 mm	
Measurement mode		High resolution mode / Normal mode *4			
Travel range (Z axis)		100 mm			
Accuracy	Measurement accuracy within the screen *1	High resolution mode	±2 μm		±1,5 μm
		Normal mode	±4 μm		±3 μm
	Repeatability within the screen (±2σ) *2	High resolution mode	±1 μm		±0,7 μm
		Normal mode	±2 μm		±1 μm
Measurement accuracy (E1xy) *1		±(3,5+0,02) μm L: arbitrary measuring length (mm)			
Monitor magnification *3		7,6X		18,9X	
Optical system	Magnification (Telecentric Optical System)		0,2X		0,5X
	Depth of focus	High resolution mode	±0,6 mm		±0,6 mm
		Normal mode	±11 mm		±1,8 mm
Working distance		90 mm			
Camera		3 million pixels, 1/2", full color			
Illumination		Transmitted light: Green LED telecentric illumination Co-axial light: White LED Ring light: 4-quadrant white LED			
Power supply		100-240VAC 50/60Hz			
Accuracy guaranteed temperature range		19-21°C			

*1 Inspected to Mitutoyo standards by focus point position.

*2 The measuring accuracy is guaranteed to be accurate within the depth of focus.

*3 For 1X digital zoom (when using the 22-inch-wide monitor)

*4 Patent registered (Japan)

Dimensions chart

Manual stage model

Unit: mm

QI-A1010D/B1010D

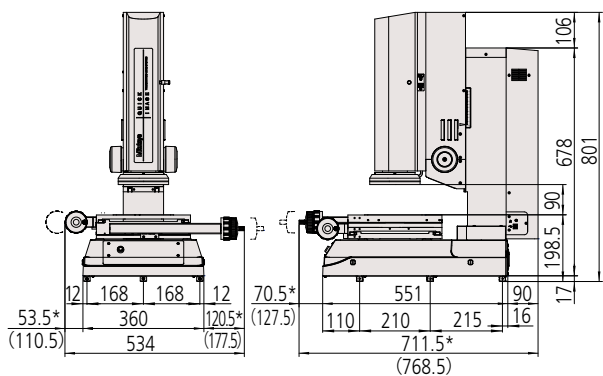

QI-A2010D/B2010D

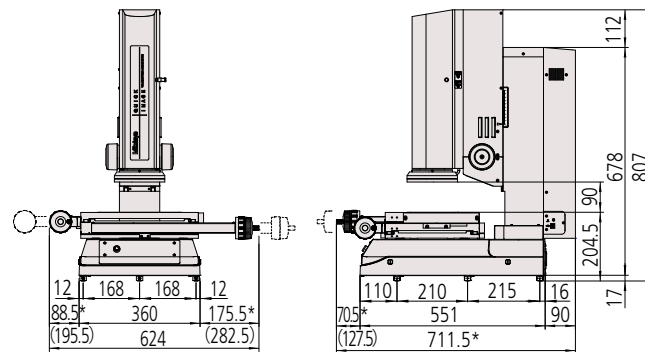

QI-A2017D/B2017D

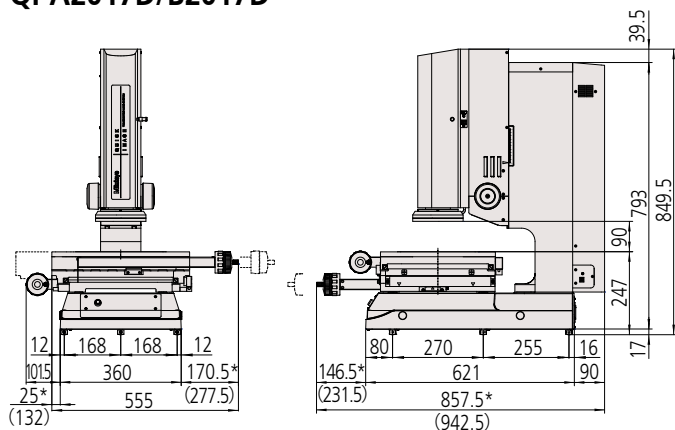

QI-A3017D/B3017D

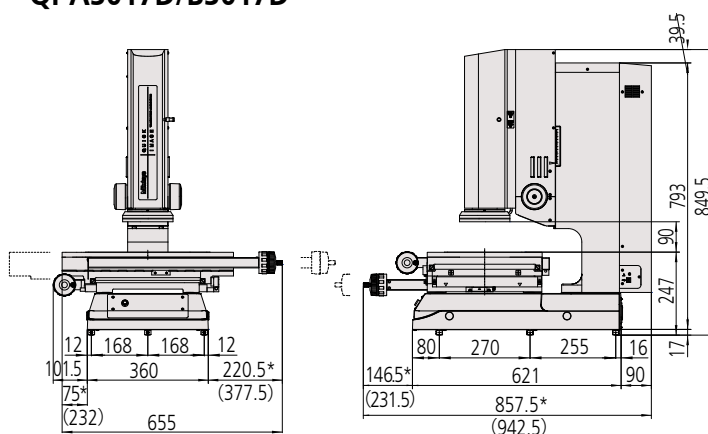

QI-A4020D/B4020D

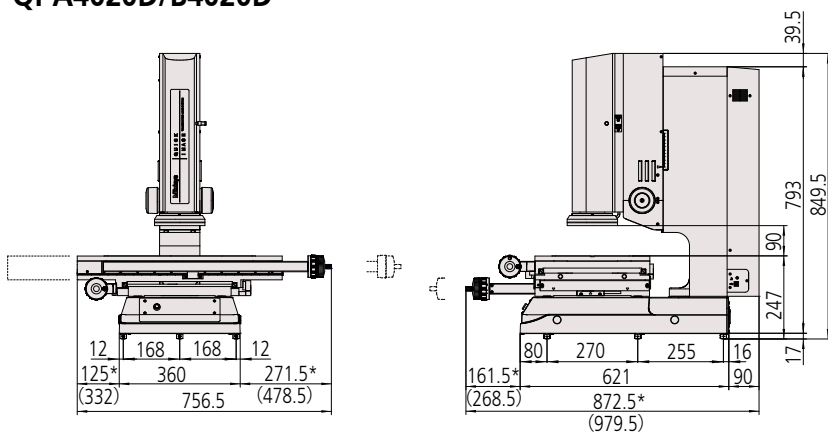

**QI-A series
QI-B series
QI-A4020D
Manual stage model**

The mounting stand (02ATX190) is optional.

*Varies depending on position of XY stage. Values in parentheses indicate maximum size.

Motorized stage model

Unit: mm

QI-C2010D

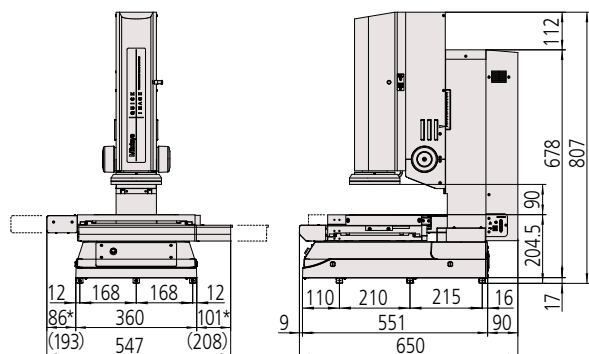

QI-C2017D

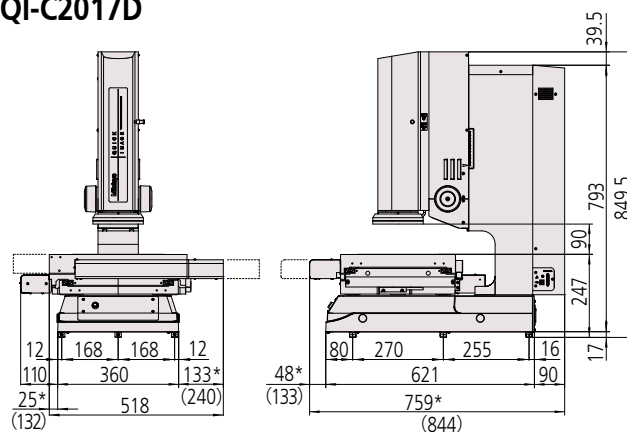

QI-C3017D

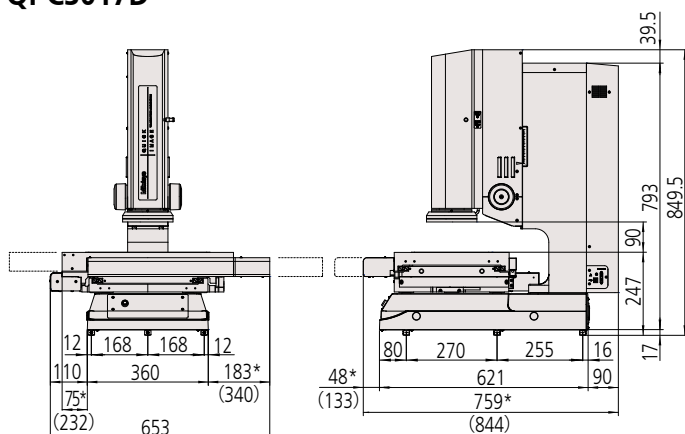

QI-C series
QI-C2017D
Motorized stage model

The mounting stand (02ATX190) is optional.

*Varies depending on position of XY stage. Values in parentheses indicate maximum size.



Whatever your challenges are, Mitutoyo supports you from start to finish.

Mitutoyo is not only a manufacturer of top quality measuring products but one that also offers qualified support for the lifetime of the equipment, backed up by comprehensive services that ensure your staff can make the very best use of the investment.

Apart from the basics of calibration and repair, Mitutoyo offers product and metrology training, as well as IT support for the sophisticated software used in modern measuring technology. We can also design, build, test and deliver bespoke measuring solutions and even, if deemed cost-effective, take your critical measurement challenges in-house on a sub-contract basis.

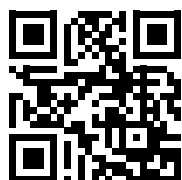

Find additional product literature and our product catalogue

www.mitutoyo.eu

Note: MITUTOYO is either registered trademarks or trademarks of Mitutoyo Corp. in Japan and/or other countries/regions. Other product, company and brand names mentioned herein are for identification purposes only and may be the trademarks of their respective holders. Product illustrations are without obligation. Product descriptions, in particular any and all technical specifications, are only binding when explicitly agreed upon.

Mitutoyo

Mitutoyo Europe GmbH

Borsigstraße 8-10
41469 Neuss

Tel. +49 (0) 2137-102-0

Fax +49 (0) 2137-102-351

info@mitutoyo.eu

www.mitutoyo.eu